

DX3 Series Insert Manual



For complete installation instructions, see the Tube Heater General Manual that accompanies this insert manual.

RE-VERBER-RAY

The DX3 Series Infrared Tube Heater is a positive pressure, single-stage radiant heater system. This insert manual is a supplement to the Tube Heater General Manual and provides specific information related to the DX3 Series model. All persons involved with the installation, operation and maintenance of the heater system must read and understand the information in this insert manual and the accompanying Tube Heater General Manual.

⚠ WARNING



Improper installation, adjustment, alteration, service or maintenance can cause property damage, injury or death. Read the installation, operation and maintenance instructions thoroughly before installing or servicing this equipment.

This heater must be installed and serviced by trained gas installation and service personnel only. Failure to comply could result in personal injury, asphyxiation, death, fire or property damage.



In locations used for the storage of combustible materials, signs must be posted to specify the maximum permissible stacking height to maintain the required clearances from the heater to the combustibles. Signs must either be posted adjacent to the heater thermostats or in the absence of such thermostats, in a conspicuous location.



Not for residential use! Do not use this heater in the home, sleeping quarters, attached garages, etc. Installation of a commercial tube heater system in residential indoor spaces may result in property damage, serious injury, asphyxiation or death.

For Your Safety

If you smell gas:

- Do not try to light any appliance.
- Do not touch any electrical switch.
- Do not use any phone in your building.
- Immediately call your gas supplier from a neighbor's phone.
- Follow the gas supplier's instructions.
- If you cannot reach your gas supplier, call the fire department.

INSTALLER: Present this manual to the end user.

Keep these instructions in a clean and dry place for future reference.

Model#: _____ Serial #: _____
(located on rating label)

LIODX3-Rev.21314
Print: 1M-10/15(CDS)
Replaces: LIODX3-5M-11/13(CDS)

Contents

1.0 Safety	3
Safety Labels and Locations	3
Clearance to Combustibles	4
2.0 Installation	6
Gas Requirements	6
Electrical Requirements	6
Wiring	7
Specifications	10
Tube Installation Sequence	11
3.0 Operation	12
Sequence of Operation	12
Thermostat	12
Operational Indicator Lights	13
4.0 Troubleshooting Guide	14
5.0 Parts	18
Components	18
Parts List	18
Kit Contents Check List	20
Approvals	20
Limited Warranty	20

NOTE: See page 10 for a list of available models and specifications.

SERVICE ACCESS PANEL
IGNITER & FLAME SENSE COMPARTMENT
 1. Turn off gas & electricity.
 2. Remove cover by lifting top cover upward and outward.
CAUTION: HOT SURFACE.
 KEEP COVER IN PLACE. REMOVE FOR SERVICE ONLY.

F/N: LLTB026

SERVICE ACCESS PANEL
CONTROLS & GAS VALVE COMPARTMENT
 1. Disconnect gas & electricity.
 2. Remove four (4) thumbscrews.
 3. Remove top cover.
 4. Swing hinged panel downward.
KEEP COVER IN PLACE. REMOVE FOR SERVICE ONLY.

F/N: LLTB024L

DX3-40-125N VERSION: 06/15
 SERIAL NUMBER: 0010000000000001 OPTIONS: None
 PRODUCTION CODE: DX3-C1

BILL OF MATERIALS

COMPONENT	PART NO.	DESCRIPTION	COMPONENT	PART NO.	DESCRIPTION
CIRCUIT BOARD	TP-8018	Fanbox	IGNITER/FAN	TP-8018	1/2" for Inducer Assy
GAS VALVE	TP-1040	24VAC Single Stage	POWER SUPPLY	TP-1040	8X Condens Collector
GAS INLET	TP-1041	1/2" NPT w/ Flare	WATER	TP-1041	WATER
IGNITER	TP-1042	Igniter	INDUCER TUBE	TP-1042	4X Inducer Tube
IND. LIGHT #1	TP-1043	Amalgam LED Ind	INDUCER BLOCK	TP-1043	Normal Box
IND. LIGHT #2	TP-1044	Green LED Ind	TRANSFORMER	TP-1044	100VA 24Vac
IND. LIGHT #3	TP-1045	None	WIRE HARNESS	TP-1045	Wire Harness

MODEL SPECIFICATIONS

MODEL SPECIFICATIONS	DATA	TUBE & REFLECTOR PARTS	
AIR ORIFICE SIZE	TP-1046 1/4"	WATER TUBE	TP-1046 1/2"
BURNER	TP-1047 Green	COMB. TUBE	TP-1047 4"
GAS ORIFICE SIZE	2# DWG	HANGERS	TP-1048 4"
1ST FUSES SWITCH	TP-1049 50-60w	REFLECTORS	TP-1049 12"
2ND FUSES SWITCH	NA	INDUCER TUBE	TP-1049 4"
WIRING DIAGRAM	LLTB110 Rev. 1	TUBE CLAMP	TP-1049 4"

Please contact the factory for assistance, parts information and/or list prices at 586-756-0950 or visit www.reverberray.com

Burner Control Box Component Label (located inside the center compartment lid)

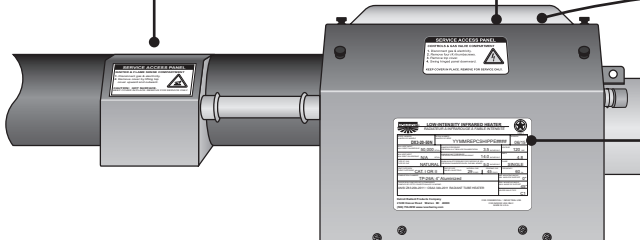

Controls Compartment

REVERBERRAY LOW-INTENSITY INFRARED HEATER
 RADIATEUR A INFRAROUGE A FAIBLE INTENSITE

MODEL NUMBER: DX3-20-50N SERIAL NUMBER: YYMMREPCSHIPPE#### DESIGN: 06/15

MAX HEAT RENT MAX HEAT CALORIFIQUE	50,000 BTU/H	MINIMUM INLET PRESSURE PRESSION D'ALIMENTATION MINIMALE	0.5 INCHES W.C.	VOLTAGE	120 VAC
MIN. HEAT RENT MIN. HEAT CALORIFIQUE	N/A	MINIMUM INLET PRESSURE PRESSION D'ALIMENTATION MINIMALE	0.5 INCHES W.C.	WINDSPEED	4.8 MPH
TYPE OF GAS TYPE DE GAZ	NATURAL	MINIMUM INLET PRESSURE PRESSION D'ALIMENTATION MINIMALE	5.0 INCHES W.C.	PHASE	SINGLE
VENT CATEGORY TYPE D'OPERATION	CAT. I OR II	MINIMUM INLET PRESSURE PRESSION D'ALIMENTATION MINIMALE	5.0 INCHES W.C.	FREQUENCY	60 Hz
COMBUSTION CHAMBER CHAMBRE DE COMBUSTION	TP-26A Naturalized	MIN. HEATING RANGE MIN. ANGLE DE SUPPORT	0°	MAX. HEATING RANGE MAX. ANGLE DE SUPPORT	45°

ANSI Z83.20b-2011 • CSA2.34b-2011 RADIANT TUBE HEATER

Detroit Radiant Products Company
 21400 Hoover Road Warren MI 48099
 (586) 756-0950 www.reverberray.com

FOR COMMERCIAL / INDUSTRIAL USE.
 FOR INDOOR USE ONLY.
 MADE IN U.S.A.

Rating Plate

SERVICE ACCESS PANEL
FAN COMPARTMENT
 1. Disconnect gas & electricity.
 2. Remove top cover (2 thumbscrews).
 3. Remove six (6) 1/4" screws.
 4. Lift and remove panel.
KEEP COVER IN PLACE. REMOVE FOR SERVICE ONLY.

F/N: LLTB025R

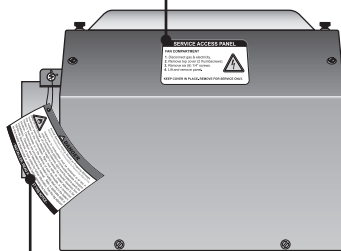

Fan Compartment

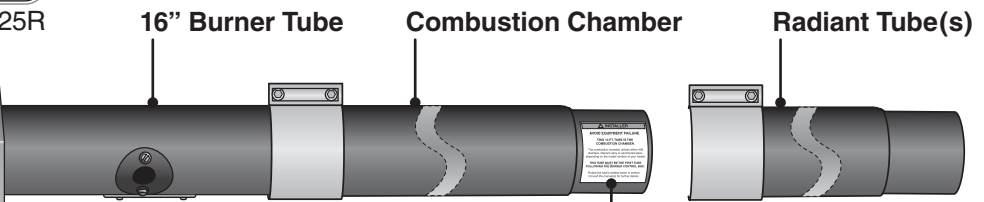

16" Burner Tube

Combustion Chamber

Radiant Tube(s)

⚠ DANGER

Avoid Serious Injury, Death or Property Damage.
 Maintain Clearances to Combustible to Prevent the Risk of Fire.

Clearance to combustibles must be maintained at all times in order to prevent the ignition of combustible materials. In locations used for the storage of combustible materials, signs must be posted to specify the maximum permissible stacking height to maintain the required clearances from the heater to the combustibles. Signs must either be posted adjacent to the heater's thermostats or in the absence of such thermostats, in a conspicuous location. Clearances are provided on the heater's safety label and in the heater's Installation, Operation and Maintenance manual. Product installation and operation must comply with applicable standards, codes and regulations. Post this tag adjacent to the heater's thermostat or controls before operating the heater.

-INSTALLER: READ AND POST THIS NOTICE-

F/N: LL01 - Clearance Safety Tag (Affix adjacent to heater's thermostat)

⚠ INSTALLER

AVOID EQUIPMENT FAILURE

THIS 10 FT. TUBE IS THE COMBUSTION CHAMBER.

The combustion chamber utilizes either 409 stainless, titanium alloy or aluminized steel - depending on the model number of your heater.

THIS TUBE MUST BE THE FIRST TUBE FOLLOWING THE BURNER CONTROL BOX.

Rotate the tube's welded seam to bottom.
 Consult the manual(s) for further details.

F/N: LLTB004 (orange)
 (150,000 - 200,000 Btu/h models only)

Clearance to Combustibles

⚠ WARNING

Placement of explosive objects, flammable objects, liquids and vapors close to the heater may result in explosion, fire, property damage, serious injury or death. Do not store or use explosive objects, liquids or vapor in the vicinity of the heater.

Clearance to combustibles is defined as the minimum distance that must exist between the tube surface, or reflector, and any combustible items (see Figure 1.1). It also pertains to the distance that must be maintained from moving objects around the tube heater. When installing the tube heater system, clearances to combustibles for the model tube heater and configuration must be maintained. Refer to Chart 1.1 to determine the required distances for your model.

Chart 1.1 • Clearance to Combustibles in Inches (see Figure 1.1 for Mounting Angles)

Model Number	Mounting Angle*	Side			
		Front	Behind	Top	Below
DX3 (20, 30, 40) - 50, 60 [N, P] with 1 side shield with 2 side shields 20 ft. from burner	0°	9	9	6	47
	45°	39	8	10	47
	0°	29	8	6	47
	0°	9	9	6	47
	0°	7	7	6	30
DX3 (20, 30, 40) - 75 [N, P] with 1 side shield with 2 side shields 20 ft. from burner	0°	9	9	6	60
	45°	39	8	10	60
	0°	29	8	6	60
	0°	9	9	6	60
	0°	7	7	6	30
DX3 (30, 40, 50) - 100 [N, P] with 1 side shield with 2 side shields 20 ft. from burner	0°	14	14	6	66
	45°	39	8	10	66
	0°	29	8	6	66
	0°	16	16	6	66
	0°	7	7	6	30
DX3 (30, 40, 50, 60) - 125 [N, P] with 1 side shield with 2 side shields 20 ft. from burner	0°	20	20	6	76
	45°	58	8	10	76
	0°	42	8	6	76
	0°	20	20	6	76
	0°	7	7	6	30
DX3 (40, 50, 60) - 150 [N, P] with 1 side shield with 2 side shields 20 ft. from burner	0°	24	24	6	81
	45°	58	8	10	81
	0°	42	8	6	81
	0°	23	23	6	81
	0°	11	11	6	44
DX3 (40, 50, 60, 70) - 175 [N, P] with 1 side shield with 2 side shields 20 ft. from burner	0°	34	34	6	92
	45°	63	8	10	92
	0°	50	8	6	92
	0°	30	30	6	92
	0°	11	11	6	44
DX3 (50, 60, 70, 80) - 200 [N, P] with 1 side shield with 2 side shields 20 ft. from burner	0°	41	41	6	94
	45°	63	8	10	94
	0°	54	8	6	94
	0°	30	30	6	94
	0°	11	11	6	44

*Heaters mounted on an angle between 0° to 45° must maintain clearances posted for 0° or 45°; whichever is greater. The stated clearance to combustibles represents a surface temperature of 90°F (50°C) above room temperature. Building materials with a low heat tolerance (such as plastics, vinyl siding, canvas, tri-ply, etc.) may be subject to degradation at lower temperatures. It is the installer’s responsibility to assure that adjacent materials are protected from degradation.

Figure 1.1 • Mounting Angles

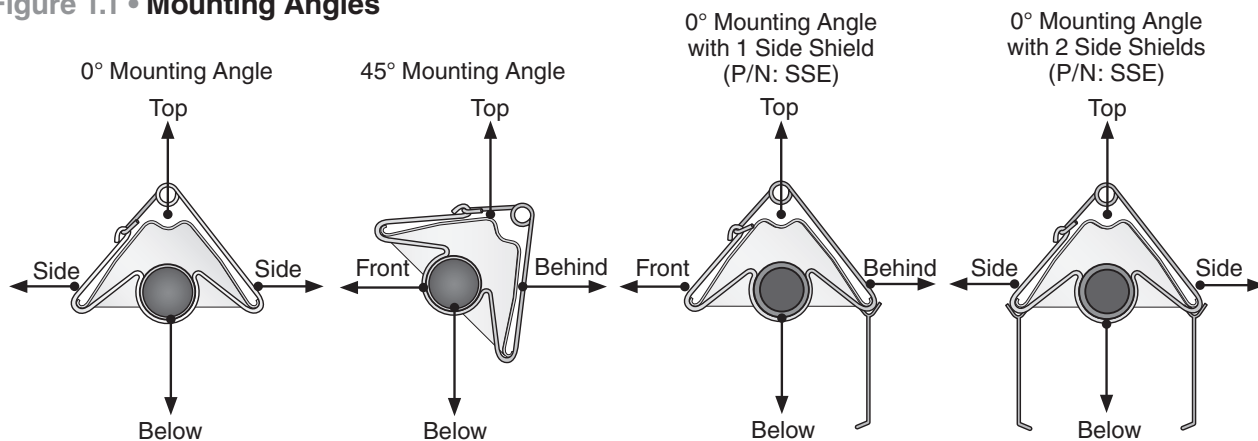

2.0 Installation

⚠ WARNING



Improper installation, adjustment, alteration, service or maintenance can cause property damage, serious injury or death. Read and understand, the installation, operating and maintenance instructions thoroughly before installing or servicing this equipment. Only trained, qualified gas installation and service personnel may install or service this equipment.

Not for residential use! Do not use this heater in the home, sleeping quarters, attached garages, etc. **Installation of a commercial tube heater system in residential indoor spaces may result in property damage, serious injury or death.**

Instructions for the following are detailed in the Tube Heater General Manual:

- Design considerations
- Hanger suspension and placement
- Tube layout and assembly
- Burner control box suspension
- Reflectors (and accessories)
- Venting and combustion air intake
- Gas requirements
- Baffle assembly

Note: Electronic versions of all manuals are available at www.detroitradiant.com

Gas Requirements

Type of Gas	Required Manifold Pressure	Minimum Inlet Pressure	Maximum Inlet Pressure
Natural	3.5 Inches W.C.	5.0 Inches W.C.	14.0 Inches W.C.
Propane	10.0 Inches W.C.	11.0 Inches W.C.	14.0 Inches W.C.



IMPORTANT: Consult the Tube Heater General Manual for gas connection requirements.

Electrical Requirements

- 120VAC - 60 Hz - 1 ph.
- Standard 120VAC thermostat connection
- Starting current 4.8 amps (FLA)
- Running current 1.1 amps (RLA)

NOTICE

The DX3 Series comes standard requiring a 120VAC thermostat connection. An optional 24VAC internal relay (24VAO) may be factory installed if the heater is to be controlled via a 24VAC thermostat. A 40VA transformer is necessary when using the 24VAO option.

NOTE: A relay transformer may be used in lieu of the factory installed 24VAO option.

Wiring

⚠ WARNING



Electric Shock

Field wiring to the tube heater must be connected and grounded in accordance with national, state, provincial, local codes and to the guidelines in the Tube Heater General Manual and Series Insert Manual. In the United States refer to the most current revisions to the ANSI/NFPA 70 Standard and in Canada refer to the most current revisions to the CSA C22.1 Part I Standard.

Figure 2.1 • Field Wiring Diagrams

A. 120V Single/Multiple Line Voltage Heater(s)

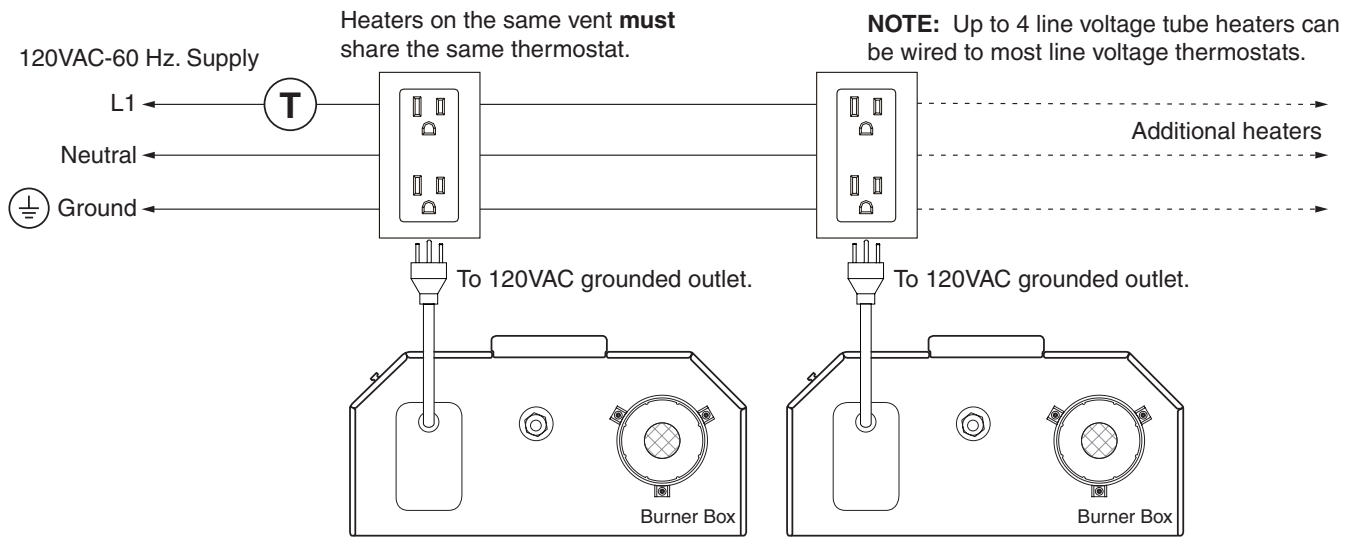

B. 24VAO (Internal Relay Option)

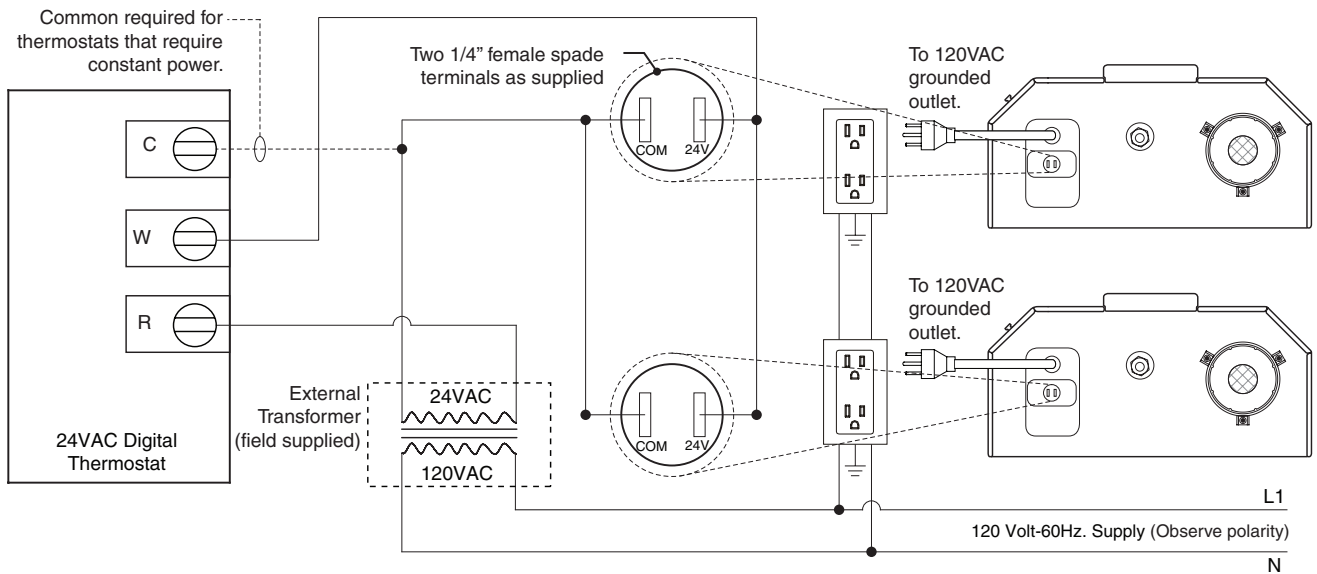

Before field wiring this appliance - Check existing wiring; replace if necessary.

NOTE: If any of the original wire supplied with the appliance must be replaced, it must be replaced with wiring material having a temperature rating of at least 105° C.

Figure 2.2 • Internal Wiring Diagram

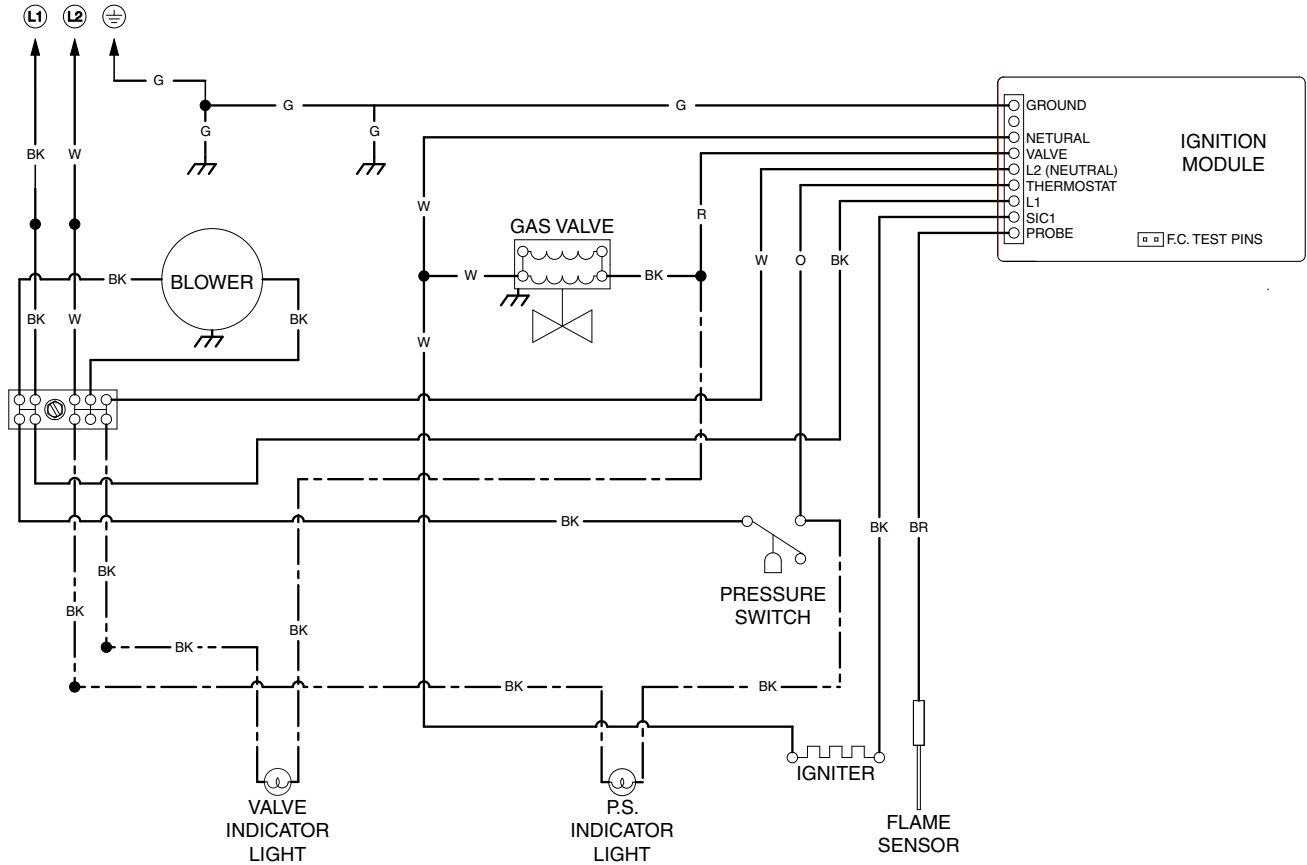

COMPONENT CODES

⊕ EARTH GROUND	☐ TRANSFORMER	⊗ PRESSURE SWITCH
⏏ CHASSIS GROUND	⊖ BLOWER MOTOR	⊗ S.P.T. RELAY
⊕ LINE VOLTAGE	⏏ HOT SURFACE IGNITER	⊕ INDICATOR LIGHT
⊖ NEUTRAL	⏏ SPARK IGNITER	⏏ GAS VALVE
● WIRE NUT	⏏ FLAME SENSOR	○ QUICK-CONNECT TERM.

WIRING COLORS:

- BK.....BLACK
- BN.....BROWN
- R.....RED
- O.....ORANGE
- Y.....YELLOW
- G.....GREEN
- BL.....BLUE
- PR.....PURPLE
- W.....WHITE
- GY.....GRAY
- PK.....PINK

WIRING INFORMATION:

LINE VOLTAGE:

- FACTORY STANDARD _____
- FACTORY OPTION - - - - -
- FIELD INSTALLED - - - - -

LOW VOLTAGE:

- FACTORY STANDARD _____
- FACTORY OPTION - - - - -
- FIELD INSTALLED - - - - -

Specifications

Chart 2.1 • Specifications

Model Number	Gas Type (Select One)	BTU/h	Straight Length	U-Tube Length	Standard Weight (lbs.)	Stainless Steel Weight (lbs.)	Recommend Mounting Height	Combustion Chamber (Black Coated)	Radiant Emitter Tube(s) (Black Coated)	Radiant Surface Area (sq. ft.)	36" Baffle Quantity
DX3-20-50	Nat or Prop	50,000	21'-9"	13'-1"	120	N/A	9' to 15'	Alum	Alum	20.2	5
DX3-20-60	Nat or Prop	60,000	21'-9"	13'-1"	120	N/A	10' to 15'	Alum	Alum	20.2	5
DX3-20-75	Nat or Prop	75,000	21'-9"	13'-1"	120	145	11' to 18'	Alum	Alum	20.2	5
DX3-30-50	Nat or Prop	50,000	31'-5"	**17'-9"	160	N/A	10' to 15'	Alum	Alum	30.4	5
DX3-30-60	Nat or Prop	60,000	31'-5"	**17'-9"	160	N/A	11' to 18'	Alum	Alum	30.4	5
DX3-30-75	Nat or Prop	75,000	31'-5"	**17'-9"	160	195	12' to 20'	Alum	Alum	30.4	5
DX3-30-100	Nat or Prop	100,000	31'-5"	**17'-9"	160	195	13' to 23'	Alum	Alum	30.4	5
DX3-30-125	Nat or Prop	125,000	31'-5"	**17'-9"	160	195	14' to 25'	Alum	Alum	30.4	6
DX3-40-50	Nat or Prop	50,000	41'-1"	22'-9"	190	N/A	11' to 18'	Alum	Alum	40.5	5
DX3-40-60	Nat or Prop	60,000	41'-1"	22'-9"	190	N/A	11' to 18'	Alum	Alum	40.5	5
DX3-40-75	Nat or Prop	75,000	41'-1"	22'-9"	190	235	12' to 20'	Alum	Alum	40.5	4
DX3-40-100	Nat or Prop	100,000	41'-1"	22'-9"	190	235	13' to 23'	Alum	Alum	40.5	4
DX3-40-125	Nat or Prop	125,000	41'-1"	22'-9"	190	235	14' to 25'	Alum	Alum	40.5	5
DX3-40-150	Nat or Prop	150,000	41'-1"	22'-9"	190	235	15' to 27'	Titan	Alum	40.5	5
DX3-40-175	Nat or Prop	*175,000	41'-1"	22'-9"	190	235	16' to 30'	Titan	Alum	40.5	5
DX3-50-100	Nat or Prop	100,000	50'-9"	**27'-5"	235	290	15' to 27'	Alum	Alum	50.6	2
DX3-50-125	Nat or Prop	125,000	50'-9"	**27'-5"	235	290	15' to 27'	Alum	Alum	50.6	3
DX3-50-150	Nat or Prop	150,000	50'-9"	**27'-5"	235	290	16' to 30'	Titan	Alum	50.6	3
DX3-50-175	Nat or Prop	*175,000	50'-9"	**27'-5"	235	N/A	17' to 35'	Titan	Alum	50.6	3
DX3-50-200	Nat or Prop	*200,000	50'-9"	**27'-5"	235	N/A	18' to 40'	Titan	Alum	50.6	2
DX3-60-125	Nat or Prop	125,000	60'-5"	32'-5"	265	330	16' to 30'	Alum	Alum	60.7	2
DX3-60-150	Nat or Prop	150,000	60'-5"	32'-5"	265	330	17' to 35'	Titan	Alum	60.7	2
DX3-60-175	Nat or Prop	*175,000	60'-5"	32'-5"	265	N/A	17' to 35'	Titan	Alum	60.7	2
DX3-60-200	Nat or Prop	*200,000	60'-5"	32'-5"	265	N/A	18' to 40'	Titan	Alum	60.7	2
DX3-70-175	Nat or Prop	*175,000	70'-1"	**37'-3"	300	N/A	19' to 42'	Titan	Alum	70.9	2
DX3-70-200	Nat or Prop	*200,000	70'-1"	**37'-3"	300	N/A	19' to 42'	Titan	Alum	70.9	2
DX3-80-200	Nat or Prop	*200,000	79'-9"	42'-1"	330	N/A	20' to 45'	Titan	Alum	81.0	2

* Model requires stainless steel tube clamp (P/N: TP-220) to be located at the seam between the primary combustion chamber and the secondary combustion tube downstream of the burner control box.

** Model requires 5EA-SUB accessory package when installing in a 'U' configuration (P/N: TF1B).

IMPORTANT: Reference box label to determine the number of required baffles sections for each model heater.

Titan = Black coated titanium stabilized aluminized steel.

Alum = Black coated aluminized treated steel.

Tube Installation Sequence

Figure 2.4 • Tube Installation Sequence

Important! The combustion chamber & radiant tube sections must be installed in the following order.

20 Foot



30 Foot

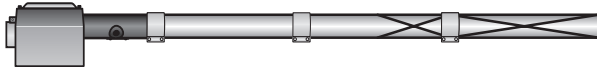

40 Foot



50 Foot

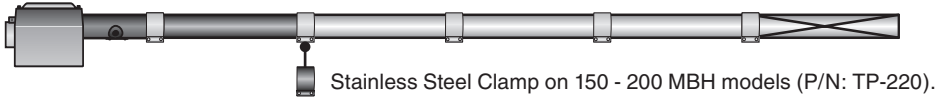

60 Foot



70 Foot



80 Foot

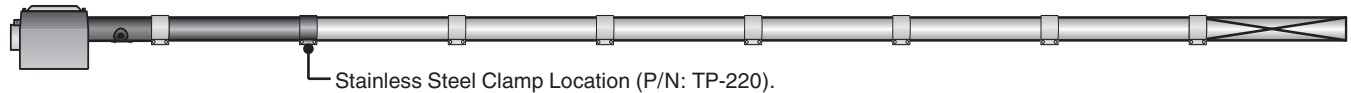

Key	
	Burner Control Box with 16-inch Burner Tube
	Black Coated Combustion Chamber Tube*
	Black Coated Aluminized Combustion Chamber/Radiant Emitter Tube
	Standard Tube Clamp
	Stainless Steel Tube Clamp (P/N: TP-220) <i>175-200 MBH models only - Located between 1st and 2nd 10 ft. tube sections.</i>
	Baffle Location

*Aluminized tubes (50,000 to 125,000 BTU/h models); Titan tubes (150,000 to 200,000 BTU/h models) .

NOTE: Refer to the Tube Heater General Manual, Chart 3.6 (page 23) for secured reflector joints.

3.0 Operation

⚠ WARNING



This heater must be installed and serviced by trained gas installation and service personnel only.

Do not bypass any safety features or the heater's built in safety mechanisms will be compromised.

NOTE: Reference the Tube Heater General Manual for installation requirements.

Sequence of Operation

Starting Circuit: Upon a call for heat, the fan is energized. Once operational static pressure is achieved, the differential switch will close initiating the ignition sequence. After a 5-second delay, the glo-bar® or "HSI" is energized for 45 seconds and the control allows the gas valve to open.

The trial for ignition is 8 seconds. If flame sense is not established within 8.5 seconds, the heater will attempt two (2) additional ignition sequences before proceeding to soft lockout. Soft lockout automatically retries after one (1) hour or the control can be reset by briefly interrupting the power source.

Running Circuit: After ignition, the flame rod monitors burner flame. If sense of flame is lost, the control immediately acts to reignite the gas-air mixture (identical to the starting sequence). If flame sense is not established within 8.5 seconds, the heater will attempt two (2) additional ignition sequences before proceeding to soft lockout. The control can be reset by briefly interrupting the power source.

Thermostat

NOTE: Different thermostats operate according to their particular features. Refer to thermostat specifications for details. Refer to Figure 2.1 for field wiring diagrams.

DX3 Series heaters with 24VAO option require a 24VAC, single-stage thermostat to operate. The burner control box is equipped with a round terminal strip that accepts two (2) 1/4" female spade terminals. Do not supply 120VAC to the 24VAC connection.

Diagnostics

Lockout:

The controls will automatically lockout the heater system when an external or system fault occurs. There are two types of lockout:

Soft Lockout: The heater will attempt to light three times. In the event of a failed attempt to light, (gas pressure, valve, no flame sense etc.), the heater will enter a soft lockout period for 15 minutes and then attempt to light three more times before entering Hard Lockout mode.

Hard Lockout: If proof of flame is not established, a component failure occurs or blockages are evident, the heater will enter hard lockout. If lockout occurs, the control can be reset by briefly interrupting the power source.

Operational Indicator Lights

The externally located operational indicator lights are provided to assist in troubleshooting of the heater. Refer to the following pages for additional troubleshooting.

Figure 3.1 • Operational Indicator Lights

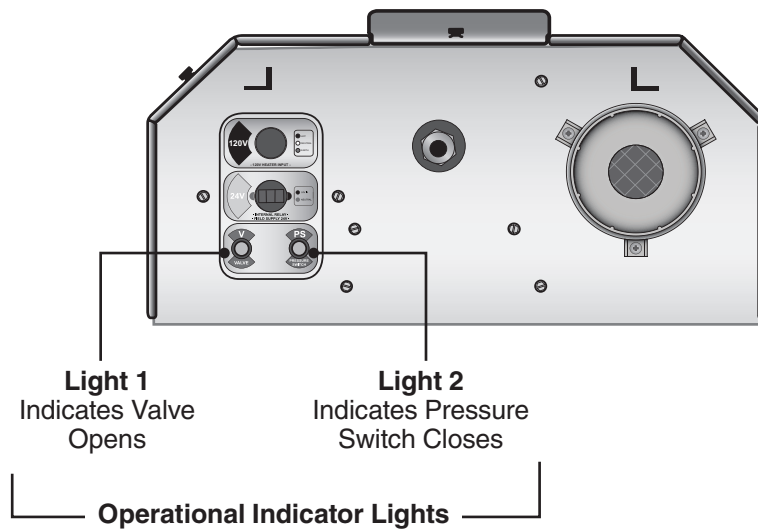

4.0 Troubleshooting Guide

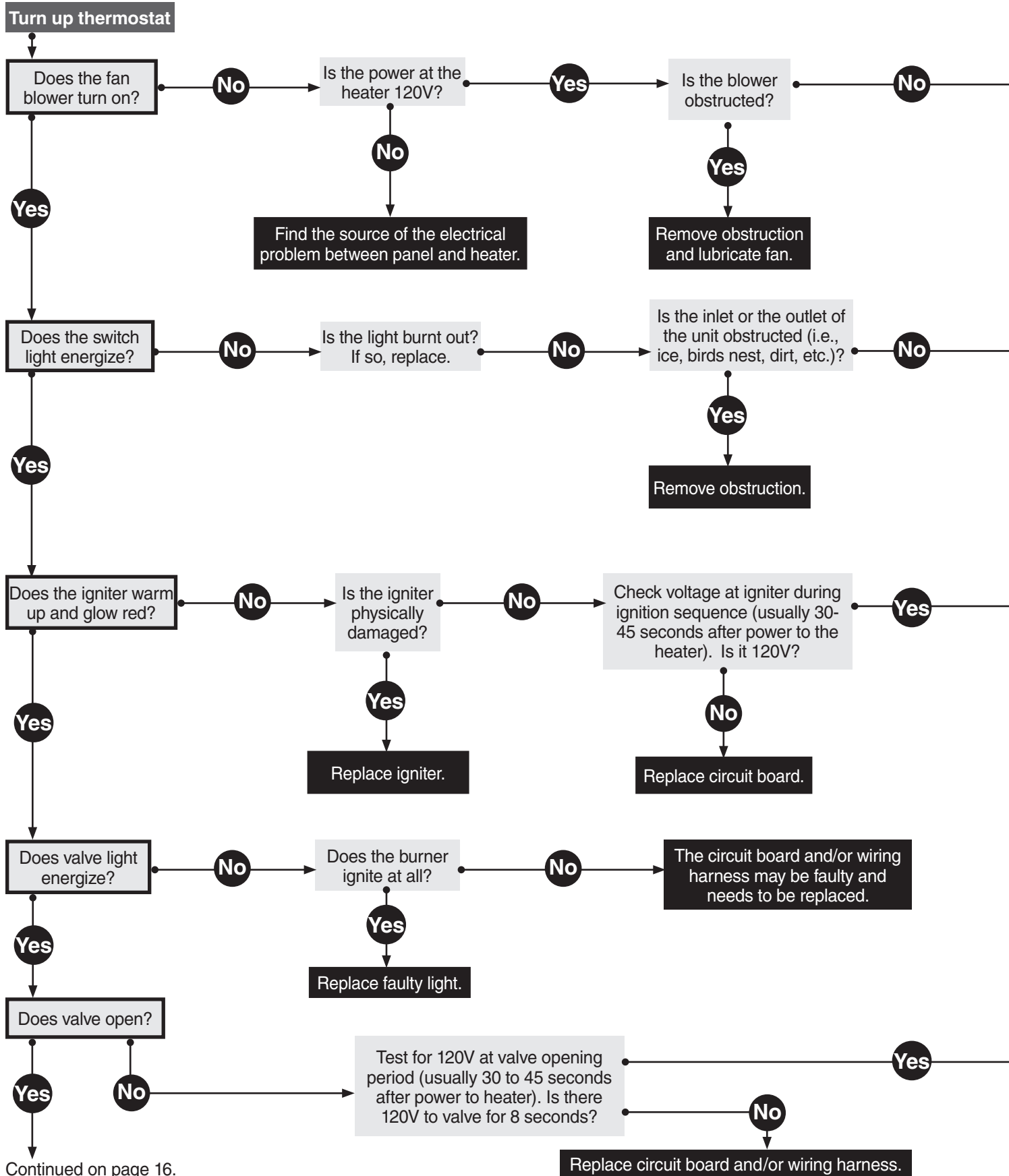

Continued on page 16.

NOTICE

Bypassing any switch is intended for testing purposes only. Do not leave switch bypassed during normal operation or the heater's built-in safety mechanisms will be compromised.

Key

- Start Question
- Process Question
- Corrective Action

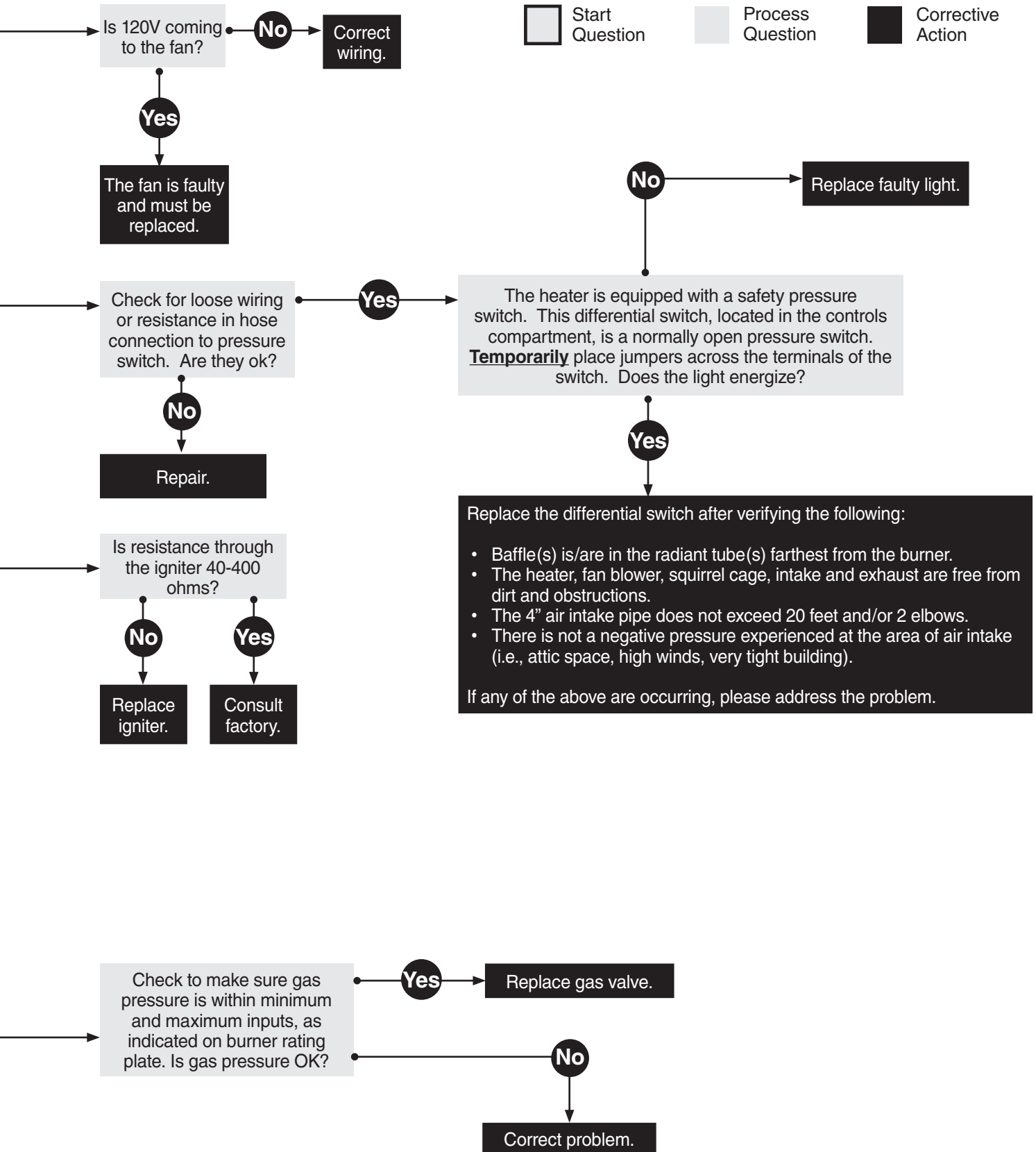

Continued from page 14

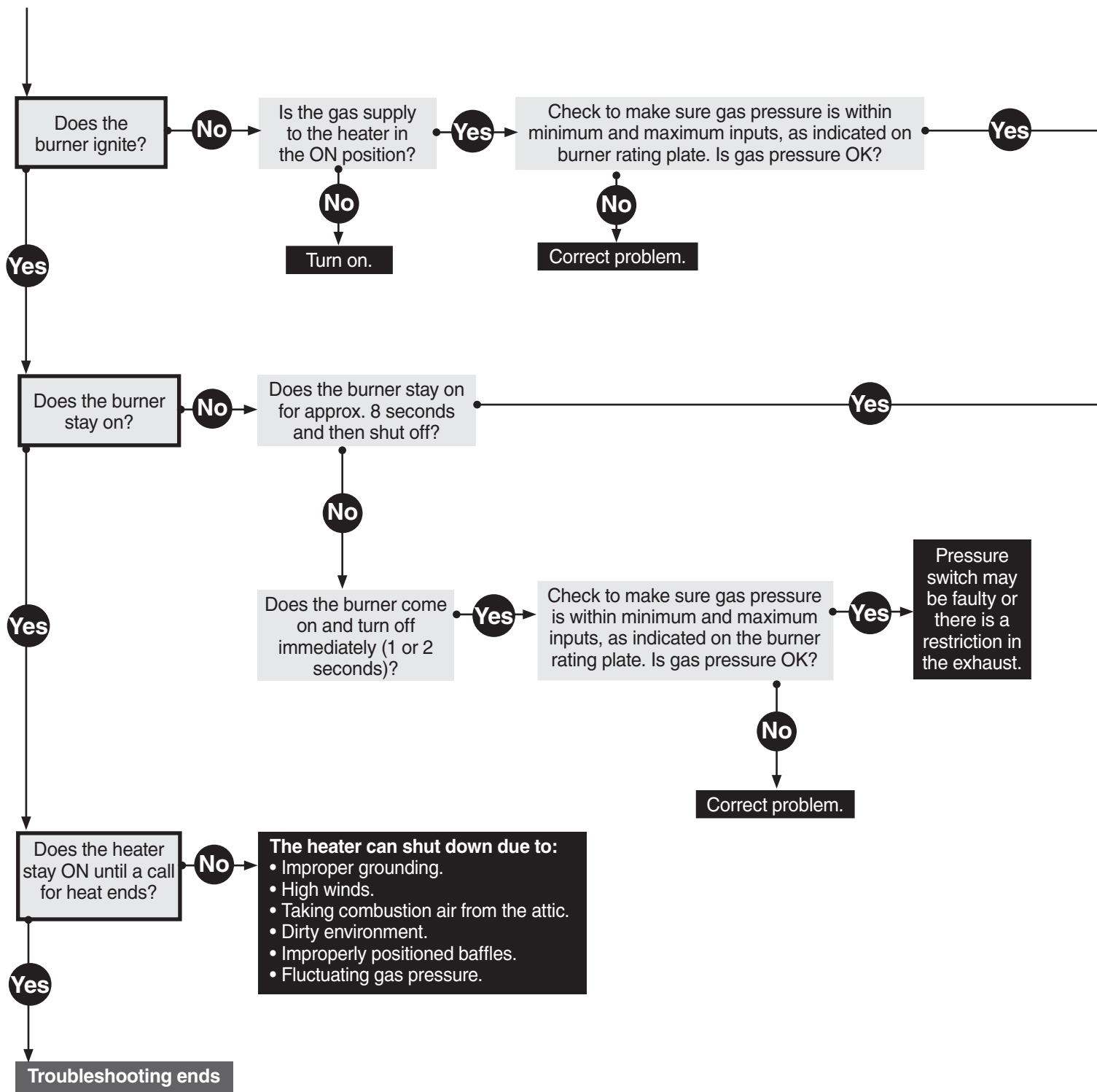

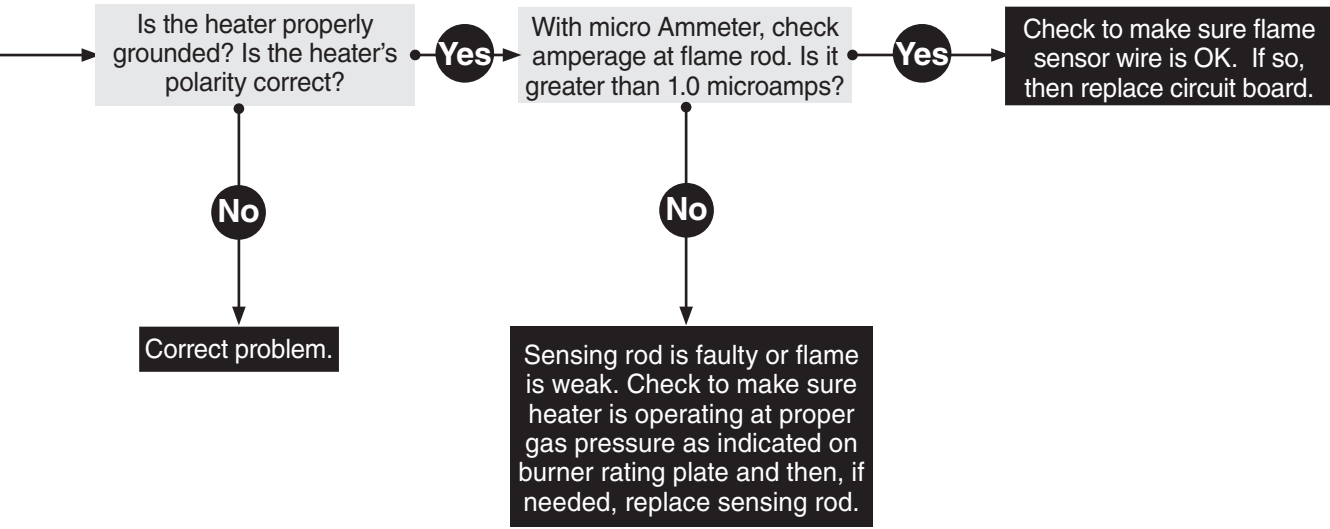
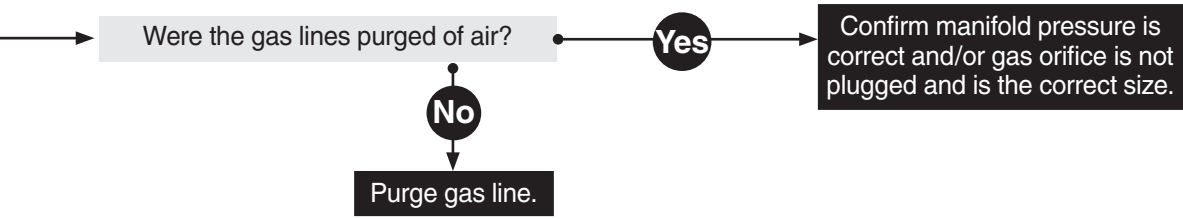

5.0 Parts

Figure 5.1 • Burner Assembly Components

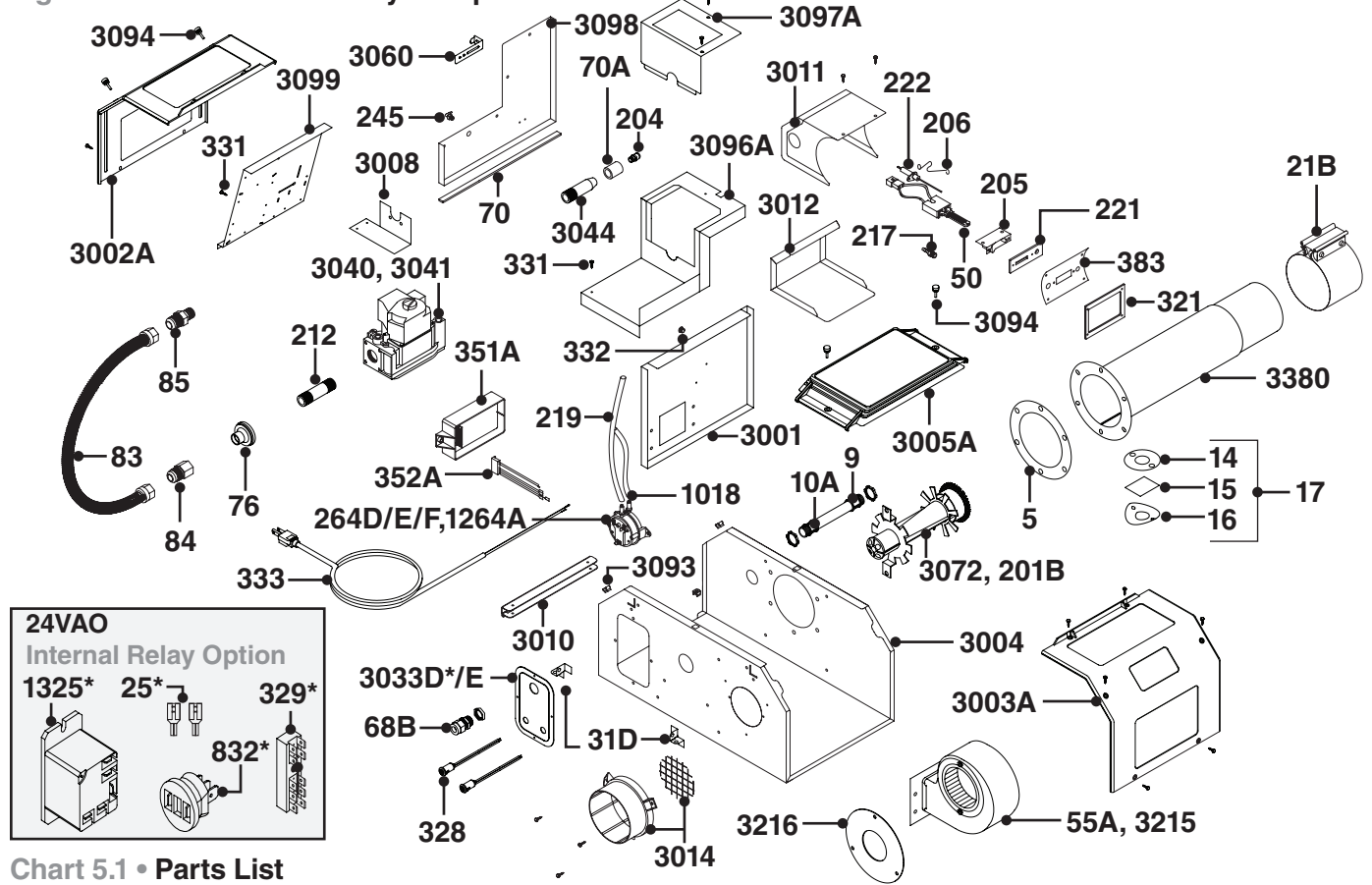
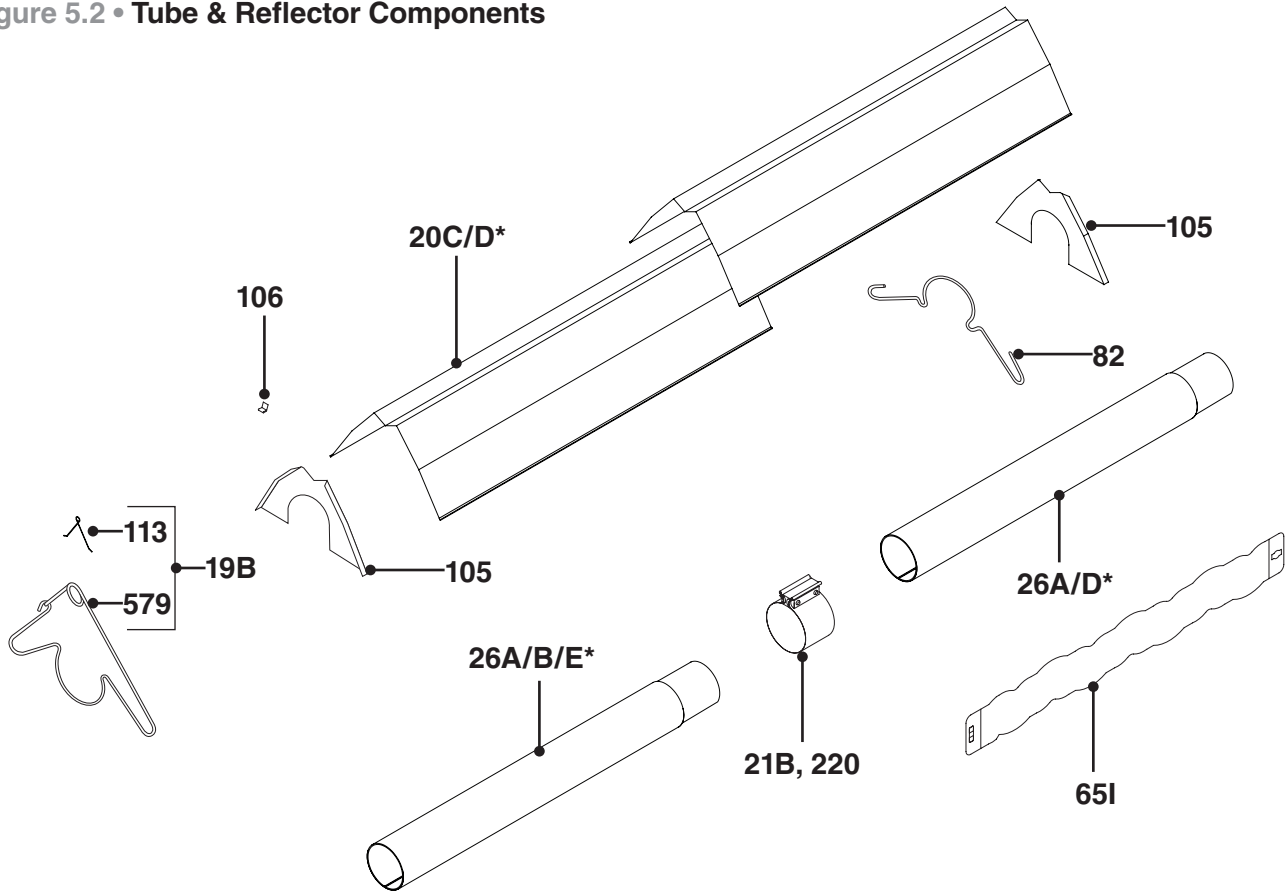

Chart 5.1 • Parts List

Part #	Description	Part #	Description
TP-5	Flange Gasket	TP-70	1/2" x 10" Control Box Gasket
TP-9	Conduit Coupling	TP-70A	1" x 6" Manifold Gasket
TP-10A	Plastic Conduit	TP-76	Rubber Grommet
TP-14	Sight Glass Gasket	TP-82	Reflector Center Support (RCS)
TP-15	Sight Glass	TP-83	1/2" x 24" C.S.S.T. Flexible Gas Connector
TP-16	Sight Glass Washer	TP-84	1/2" N.P.T (Female) to Male Flare Fitting
TP-17	Sight Glass Kit	TP-85	1/2" N.P.T. (Male) to Male Flare Fitting
TP-19B	4" Wire Hanger with Tension Spring	TP-105	Aluminum Reflector End Cap
TP-20C	10 ft. Polished Aluminum Reflector	TP-106	Reflector End Cap Clips (8 pcs.)
TP-20D*	120 in. Stainless Steel Reflector	TP-113	Reflector Tension Spring
TP-21B	4" Standard Tube Clamp	TP-201B	Mid-High Burner (Color Code - TAN)
TP-25*	1/4" Female Spade Terminal (Qty. 2)	TP-204	Gas Orifice (consult factory)
TP-26A	10 ft. Aluminized Radiant / Combustion Tube	TP-205	Glo-Bar™ Holder
TP-26B	10 ft. Titanium Stabilized Combustion Tube	TP-206	Glo-Bar™ Holder Spring Clip
TP-26D*	10 ft. 304 Stainless Steel Radiant Tube	TP-212	1/2" N.P.T. x 3" Pipe Nipple
TP-26E*	10 ft. 409 Stainless Steel Combustion Tube	TP-217	1/8" N.P.T. Brass Barb Fitting
TP-31D	Interlocking Mounting Bracket (Qty. 2)	TP-219	12" Pneumatic Tube for Pressure Switch
TP-50	Glo-Bar™ Igniter	TP-220	Stainless Steel Tube Clamp (150- 200 MBH)
TP-55A	1/20 hp Inducer Assembly (50-150 MBH)	TP-221	Glo-Bar™ Holder Gasket
TP-65I	3 ft. Interlocking Turbulator Baffle	TP-222	Flame Rod
TP-68B	1/2" Strain Relief Bushing	TP-245	1/8" Plastic N.P.T. 90° Barb Fitting

* Optional upgrade or add-on item.

Figure 5.2 • Tube & Reflector Components







Part No.	Description	Part No.	Description
TP-264D	Differential Pressure Switch, 60 to 75 MBH	TP-3008	Gas Valve Mounting Bracket
TP-264E	Differential Pressure Switch, 50 MBH	TP-3010	Service Panel Hinge
TP-264F	Differential Pressure Switch, 150 to 200 MBH	TP-3011	Igniter Box
TP-321	Ignition Plate Gasket	TP-3012	Igniter Box Cover
TP-328	120VAC Yellow Indicator Light (Qty. 2)	TP-3014	Plastic Air Orifice with Screen
TP-329*	1/4" Male Spade Terminal Block	TP-3033D*	Power Entry Plate*
TP-331	Green Self-Tap Ground Screw (Qty. 2)	TP-3033E	DX3 Power Entry Plate
TP-332	1/4" Divider Grommet	TP-3040	Gas Valve - Natural Gas
TP-333	60" Black 120V Power Cord with Ground	TP-3041	Gas Valve - Propane Gas
TP-351A	Potted Circuit Board	TP-3044	Gas Manifold
TP-352A	Wire Harness for Ignition Controller	TP-3060	Pressure Switch Mounting Bracket
TP-383	Glo-Bar™ Igniter Plate	TP-3072	Low BTU Burner (Color Code - GREEN)
TP-579	4" Wire Hanger w/o Tension Spring	TP-3093	#8-32 Cage Nut (Qty. 4)
TP-832*	Thermostat Terminal Strip	TP-3094A	#8-32 x 1/2" Metal Thumb Screw (Qty. 4)
TP-1018	20" Pneumatic Tube for Pressure Switch	TP-3096A	Valve Compartment Bottom Panel
TP-1264A	Differential Pressure Switch, 100 to 125 MBH	TP-3097A	Valve Compartment Top Panel
TP-1325*	24V Coil Relay	TP-3098	Valve Compartment Side Panel
TP-3001	Divider Panel	TP-3099	Controls Mounting Panel
TP-3002A	Plastic End Panel, Control Compartment	TP-3215	1/15 hp Inducer Assembly (175-200 MBH)
TP-3003A	Plastic End Panel, Fan Compartment	TP-3216	Reducer Plate (175-200 MBH)
TP-3004	Control Box	TP-3380	16" HSI Burner Tube w/Flange and Fittings
TP-3005A	Plastic Valve Chamber Lid		

* Optional upgrade or add-on item.

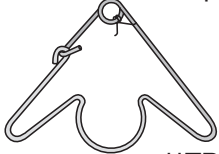
Kit Contents Check List

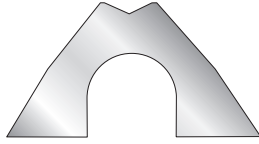
Chart 5.2 • Kit Contents for DX3 Series - Reference the length column for your model.

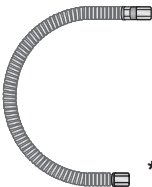
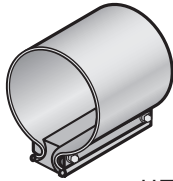
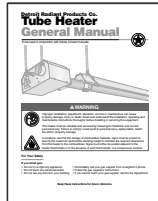
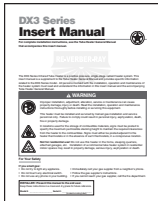
DX3 Series Kit Contents								
<p>TP-19B 4" Hanger with Reflector Tension Spring</p>  <p>**TP-19C</p>	<p>TP-82 4" Reflector Center Support (RCS)</p>  <p>**TP-829</p>	<p>TP-105 Reflector End Cap</p>  <p>**TP-105A</p>	<p>TP-106 Reflector End Cap Clips</p> 	<p>TP-83 24" Stainless Steel Flexible Gas Connector</p>  <p>**TP-83A</p>	<p>TP-21B 4" Tube Clamp</p>  <p>**TP-220</p>	<p>LIOGT3 Tube Heater General Manual</p> 	<p>LIODX3 DX3 Series Insert Manual</p> 	
Part No.	Description	20 ft.	30 ft.	40 ft.	50 ft.	60 ft.	70 ft.	80 ft.
TP-19B	4" Hanger w/ Tension Spring	3	4	5	6	7	8	9
TP-21B	4" Tube Clamp	2	3	4*	5*	6*	7*	8*
TP-82	4" Reflector Center Support	2	3	4	5	6	7	8
TP-83	24" S.S. Flexible Gas Connector	1	1	1	1	1	1	1
TP-105	Reflector End Cap	2	2	2	2	2	2	2
TP-106	Reflector End Cap Clips	8	8	8	8	8	8	8
LIOGT3	General Tube Heater Manual	1	1	1	1	1	1	1
LIODX3	DX3 Series Insert Manual	1	1	1	1	1	1	1
Additional kit contents as supplied when heater is configured with Add-On Options (if applicable)								
TP-25	1/4" Female Spade Terminal (24VAO)	2	2	2	2	2	2	2
Filled By:								

* **NOTE:** One 4" stainless steel tube clamp (P/N: TP-220) is provided for each 150,000 - 200,000 BTU/h model. Place as shown on page 11.

** Part number for models upgraded with stainless steel options.

Approvals

- CSA.
- Indoor approval.
- Outdoor approval with OD-Kit.
- Commercial approval.

Limited Warranty

- 1 year - Burner box components.
- 5 years - Combustion and radiant tubes.
- 10 years - Stainless steel burner.
- See page 36 of the General Tube Heater Manual for terms and conditions.



© 2015 Detroit Radiant Products Co.
 21400 Hoover Road • Warren, MI 48089
 Phone: (586) 756-0950 Fax: (586) 756-2626
 www.detroitradiant.com • sales@drp-co.com