

# HL2 Series Insert Manual



For complete installation instructions, see the Tube Heater General Manual that accompanies this Series Insert Manual.

**RE-VERBER-RAY**  
by Detroit Radiant Products Company

The HL2 Series Infrared Tube Heater is a positive pressure, two stage radiant heater system. This insert manual is a supplement to the Tube Heater General Manual and provides specific information related to the HL2 Series model. All persons involved with the installation, operation and maintenance of the heater system must read and understand the information in this insert manual and the accompanying Tube Heater General Manual.

## ⚠ WARNING



Improper installation, adjustment, alteration, service, or maintenance can cause property damage, injury, or death. Read the installation, operation, and maintenance instructions thoroughly before installing or servicing this equipment.

This heater must be installed and serviced by trained gas installation and service personnel only. Failure to comply could result in personal injury, asphyxiation, death, fire, or property damage.



In locations used for the storage of combustible materials, signs must be posted to specify the maximum permissible stacking height to maintain the required clearances from the heater to the combustibles. Signs must either be posted adjacent to the heater thermostats or, in the absence of such thermostats, in a conspicuous location.



**Not for residential use!** Do not use this heater in the home, sleeping quarters, attached garages, etc. **Installation of a commercial tube heater system in residential indoor spaces may result in property damage, serious injury, asphyxiation or death.**

### For Your Safety

#### If you smell gas:

- Do not try to light any appliance.
- Do not touch any electrical switch.
- Do not use any phone in your building.
- Immediately call your gas supplier from a neighbor's phone.
- Follow the gas supplier's instructions.
- If you cannot reach your gas supplier, call the fire department.

#### **INSTALLER: Present this manual to the end user.**

Keep these instructions in a clean and dry place for future reference.

Model#: \_\_\_\_\_ Serial #: \_\_\_\_\_  
(located on rating label)

LIOHL2a-Rev. 15225

Print: XM-11/25 (CDS)

Replaces: LIOHL2-Rev. 24414-1M-01/20(CDS)

# Contents

---

<b>1.0 Safety</b> .....	<b>3</b>
Safety Labels and Their Locations .....	3
Clearances to Combustibles .....	4
<b>2.0 Installation</b> .....	<b>6</b>
Gas Requirements .....	6
Electrical Requirements .....	6
Wiring .....	7
Specifications .....	10
Tube Installation Sequence .....	11
<b>3.0 Operation</b> .....	<b>12</b>
Sequence of Operation .....	12
Thermostat .....	12
Diagnostics .....	13
<b>4.0 Troubleshooting Guide</b> .....	<b>14</b>
<b>5.0 Parts</b> .....	<b>18</b>
Components .....	18
Parts List .....	18
Kit Contents Check List .....	20
Approvals .....	20
Limited Warranty .....	20

**NOTE:** See page 10 for a list of available models and specifications.

## **WARNING**

### **California Proposition 65**

This product can expose you to chemicals including lead and carbon monoxide, which are known to the State of California to cause birth defects or other reproductive harm.

For more information, go to [www.P65Warnings.ca.gov](http://www.P65Warnings.ca.gov).

# 1.0 Safety

## ⚠ WARNING



Improper installation, adjustment, alteration, service, or maintenance can cause property damage, serious injury, or death. Read and understand the installation, operation, and maintenance instructions thoroughly before installing or servicing this equipment. Only trained, qualified gas installation and service personnel may install or service this equipment.

## Safety Labels and Their Locations

Product safety signs or labels should be replaced by the product user when they no longer are legible. Contact either your local distributor or the product manufacturer for obtaining replacement signs or labels.

**Back Panel**

**Rating Plate**

DETROIT RADIANT INFRA-RED RADIANT TUBE HEATER	
FOR OUTDOOR USE AND MOORING (See Pressure Installation Chart)	
Class I/A Permanent Label	
MODEL NO.	HL2-40-125N
INPUT BTU/H	125,000 / 82,000
VOLTS AC	120V - 60Hz
AMPS - Starting	4.8
AMPS - Running	1.1
Combustion Chamber	4" BC Alumirized
DESIGN COMPLIES WITH	ANSI Z83.20-2008 GAS FIRED LOW INTENSITY INFRA-RED HTR.
DETROIT RADIANT PRODUCTS COMPANY	27400 DETROIT RD. WARREN, MI 48090-1500
Serial No.	0914XXXXXXX0001

**Top Panel**

F/N: LLT018 (Natural Gas)  
F/N: LLT019 (Propane Gas)

**Bottom Panel**

**HL2-40-125N**

Production Code: HL2-125  
Version: 9.14

Serial No.: 0914XXXXXXX0001  
Stock: None  
Add-On: N/A

Data on this label is for the model shown on this label. If your heater has been converted, this information is not accurate. Please contact the factory for assistance.

BURNER COMPONENTS: (Specify TP-F's)	
Gas Valve:	3E66-224-N 840
Circuit Board:	Micro60-24 851
Wire Harness:	3-PC3 Harness 852
N.O. Switch:	None
N.C. Switch:	None
N.C. V.L. Orifice:	None
N.C. V.L. Orifice:	None
Diff. Switch:	8520-1000-00 264E
Diff. V.L. Orifice:	Gray 1/4" 360
Igniter:	Norton 50
Warranty:	Low Mile 3072
W.C. Label:	4" Gas 360
Ind. Lights:	Yellow - 120V

HEATER TYPE: C1  
Orifice Type: C1 C2 C3  
Internal Use Only: Gas: TP-2048 3 3 3  
Air: TP-442 1.1 2.7 1.5 1.8

Electric: LLWT038  
Special 1: Micro60  
Special 2: Plug-In

For parts replacement information, contact factory at 586-756-0950 or visit www.drp-co.com/parts.

**Bottom Panel**

F/N: LLTCL001 Clearances to Combustibles Label

**Bottom Panel**

F/N: LLLOG032

**Bottom Panel**

**RE-VERBER-RAY**  
by Detroit Radiant Products Company  
INFRA-RED RADIANT HEATERS

F/N: LLTB007(2)

LED CODE	FAULT STATUS	FAULT CODE DELAY
Initial flash on power up, then steady off	Normal operation	Immediate
Steady on	Module failure / Internal fault	Immediate
1 flash	Ignition failure	30-32 minutes
2 or 3 flashes	APS - Note: fan / intake / exhaust	10-12 minutes
4 flashes	Solenoid valve fault / Leaky valve / Flame amplifier fault	Immediate
No flash on 117V start up	Transformer fault	Immediate

**CAUTION**

**Provide 24 Volts Only**

This heater has a 24 Volt control system. Do not connect 120 Volt power supply, as it will damage the controls.

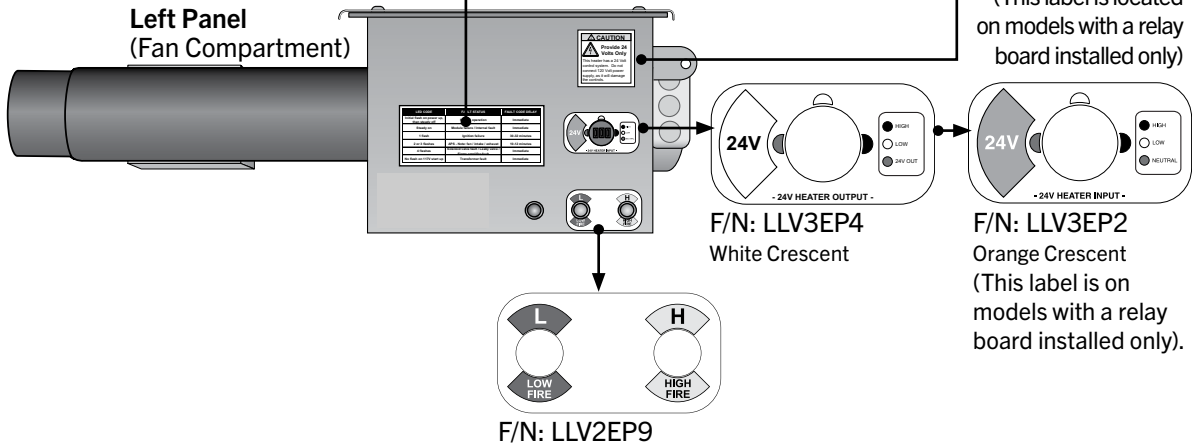

F/N: LLDR003  
(This label is located on models with a relay board installed only)

F/N: LLV3EP2  
Orange Crescent  
(This label is on models with a relay board installed only).

F/N: LLV2EP9

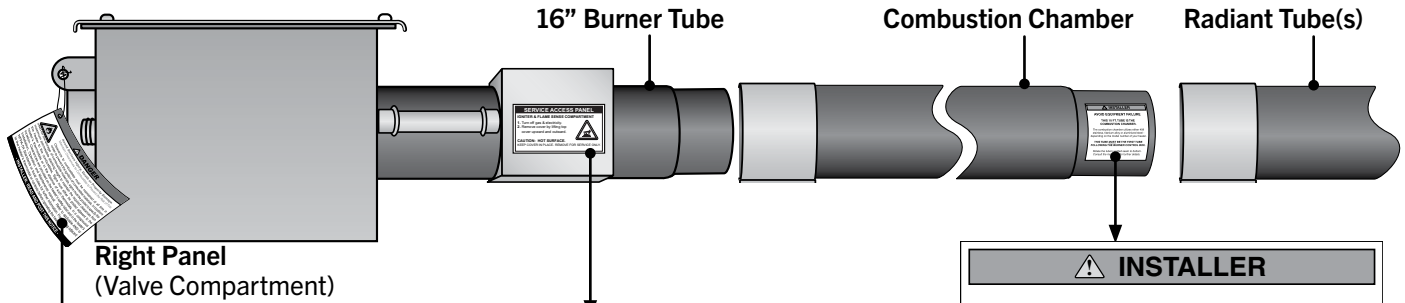

Right Panel  
(Valve Compartment)

**WARNING**

Avoid Serious Injury, Death, or Property Damage. Maintain Clearances to Combustible to Prevent the Risk of Fire.

Clearances to combustibles must be maintained at all times in order to prevent the ignition of combustible materials. In locations used for the storage of combustible materials, signs must be posted to specify the maximum permissible stacking height to maintain the required clearances from the heater to the combustibles. Signs must either be posted adjacent to the heater's thermostats or, in the absence of such thermostats, in a conspicuous location. Clearances are provided on the heater's safety label and in the heater's Installation, Operation, and Maintenance manual. Product installation and operation must comply with applicable standards, codes, and regulations. Post this tag adjacent to the heater's thermostat or controls before operating the heater.

California Proposition 65

This product can expose you to chemicals including lead and carbon monoxide, which are known to the State of California to cause birth defects or other reproductive harm.

For more information go to [www.P65Warnings.ca.gov](http://www.P65Warnings.ca.gov).

- INSTALLER: READ AND POST THIS NOTICE -

F/N: LL001 - Clearance Safety Tag  
(Affix adjacent to heater's thermostat)

**SERVICE ACCESS PANEL**  
IGNITER & FLAME SENSE COMPARTMENT

1. Turn off gas & electricity.
2. Remove cover by lifting top cover upward and outward.

**CAUTION: HOT SURFACE.**  
KEEP COVER IN PLACE. REMOVE FOR SERVICE ONLY.

F/N: LLTB026

**INSTALLER**

**AVOID EQUIPMENT FAILURE**

**THIS 10 FT. TUBE IS THE COMBUSTION CHAMBER.**

The combustion chamber utilizes either 409 stainless, titanium alloy or aluminized steel - depending on the model number of your heater.

**THIS TUBE MUST BE THE FIRST TUBE FOLLOWING THE BURNER CONTROL BOX.**

Rotate the tube's welded seam to bottom.  
Consult the manual(s) for further details.

F/N: LLTB004 (orange)

## Clearances to Combustibles

**WARNING**

Placement of explosive objects, flammable objects, liquids, and vapors close to the heater may result in explosion, fire, property damage, serious injury, or death. Do not store or use explosive objects, liquids, or vapors in the vicinity the heater.

**Clearances to combustibles** is defined as *the minimum distance that must exist between the tube surface, or reflector, and any combustible items* (see Figure 1.1). It also pertains to the distance that must be maintained from moving objects around the tube heater.

When installing the tube heater system, clearances to combustibles for the model tube heater and configuration must be maintained. Refer to Chart 1.1 below to determine the required distances for your model.

**Chart 1.1 • Clearances to Combustibles in Inches** (see Figure 1.1 for Mounting Angles)

Model Number	Mounting Angle*	Sides		Top	Below
		Front	Behind		
HL2 (20, 30, 40) - (65, 75) [N, P] with 1 side shield with 2 side shields 20 ft. from burner	0°	9	9	6	60
	45°	39	8	10	60
	0°	29	8	6	60
	0°	9	9	6	60
	0°	7	7	6	30
HL2 (20, 30, 40) - (80, 96, 100) [N, P] with 1 side shield with 2 side shields 20 ft. from burner	0°	14	14	6	66
	45°	39	8	10	66
	0°	29	8	6	66
	0°	16	16	6	66
	0°	7	7	6	30
HL2 (30, 40, 50) - 125 [N, P] with 1 side shield with 2 side shields 20 ft. from burner	0°	20	20	6	76
	45°	58	8	10	76
	0°	42	8	6	76
	0°	20	20	6	76
	0°	7	7	6	30
HL2 (40, 50, 60) - 150 [N, P] with 1 side shield with 2 side shields 20 ft. from burner	0°	24	24	6	81
	45°	58	8	10	81
	0°	42	8	6	81
	0°	23	23	6	81
	0°	11	11	6	44
HL2 (40, 50, 60, 70) - 175 [N, P] with 1 side shield with 2 side shields 20 ft. from burner	0°	34	34	6	92
	45°	63	8	10	92
	0°	50	8	6	92
	0°	30	30	6	92
	0°	11	11	6	44
HL2 (50, 60, 70) - 200 [N, P] with 1 side shield with 2 side shields 20 ft. from burner	0°	41	41	6	94
	45°	63	8	10	94
	0°	54	8	6	94
	0°	30	30	6	94
	0°	11	11	6	44

\*Heaters mounted on an angle between 0° and 45° must maintain clearances posted for 0° or 45°; whichever is greater.

The stated clearances to combustibles represent a surface temperature of 90°F (50°C) above room temperature. Building materials with a low heat tolerance (such as plastics, vinyl siding, canvas, tri-ply, etc.) may be subject to degradation at lower temperatures. It is the installer’s responsibility to ensure that adjacent materials are protected from degradation.

**Figure 1.1 • Mounting Angles**

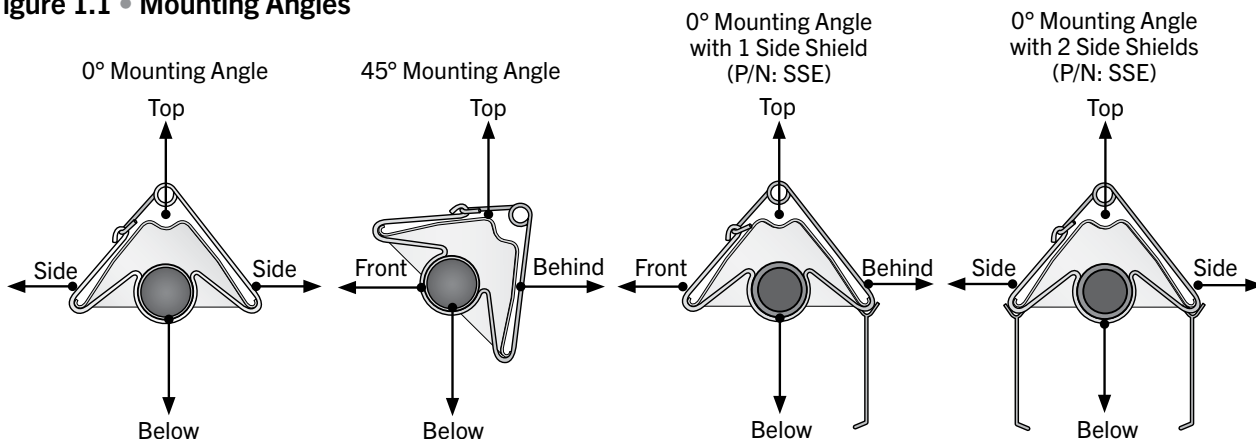

## 2.0 Installation

### ⚠ WARNING



Improper installation, adjustment, alteration, service, or maintenance can cause property damage, serious injury, or death.

Read and understand the installation, operating, and maintenance instructions thoroughly before installing or servicing this equipment.

Only trained, qualified gas installation and service personnel may install or service this equipment.

Instructions for the following are detailed in the Tube Heater General Manual:

- Design considerations
- Hanger suspension and placement
- Tube layout and assembly
- Burner control box suspension
- Reflectors (and accessories)
- Venting and combustion air intake
- Gas requirements
- Baffle assembly

**Note:** Electronic versions of all manuals are available at [www.detroitradiant.com](http://www.detroitradiant.com)

### Gas Requirements

Type of Gas	Required Manifold Pressure	Minimum Inlet Pressure	Maximum Inlet Pressure
Natural	3.5 Inches W.C.	5.0 Inches W.C.	14.0 Inches W.C.
Propane	10.0 Inches W.C.	11.0 Inches W.C.	14.0 Inches W.C.



**IMPORTANT:** Consult the Tube Heater General Manual for gas connection requirements.

### Electrical Requirements

- 120 VAC, 60 Hz GRD, 3-wire
- 24 V thermostat connection
- Starting current: 4.8 amps
- Running current: 1.1 amps

### NOTICE

Connecting the thermostat with a voltage other than 24 V may damage the heater. The HL2 Series requires a 24 V connection to the thermostat. This is either supplied by the heater internally (standard) or by an external transformer (with optional relay board, P/N: HLRP). See Figure 2.1.

# Wiring

## ⚠ WARNING



### Electric Shock

Field wiring to the tube heater must be connected and grounded in accordance with national, state, provincial, and local codes, and to the guidelines in the Tube Heater General Manual and Series Insert Manual. In the United States refer to the most current revisions to the ANSI/NFPA 70 Standard and in Canada refer to the most current revisions to the CSA C22.1 Part I Standard.

**Figure 2.1 • Field Wiring Diagrams**

**A. Single Heater, Single Thermostat. No Relay Board (white label)**

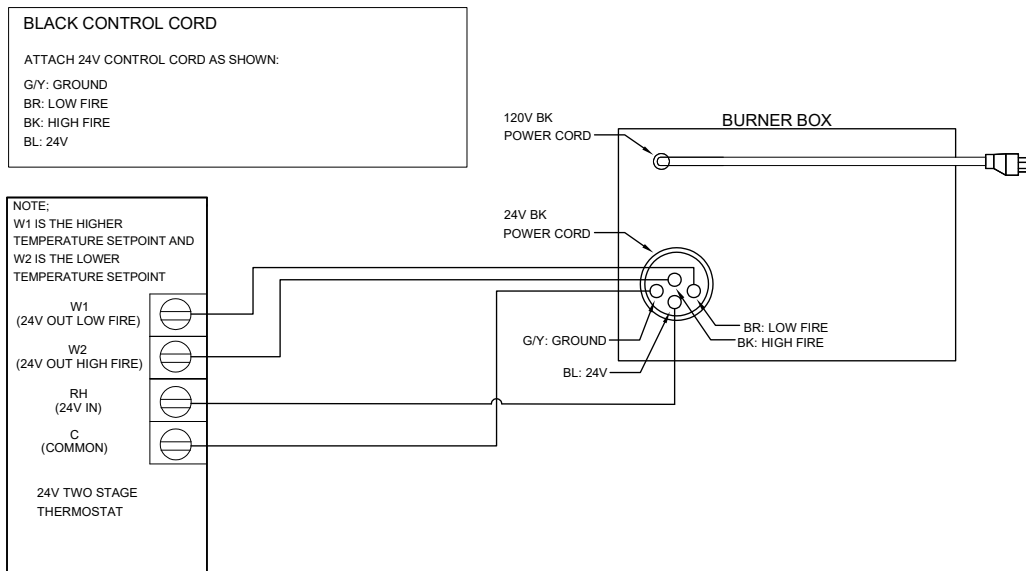

**B. Multiple Heaters, Single Thermostat. With a Relay Board (HLRP)**

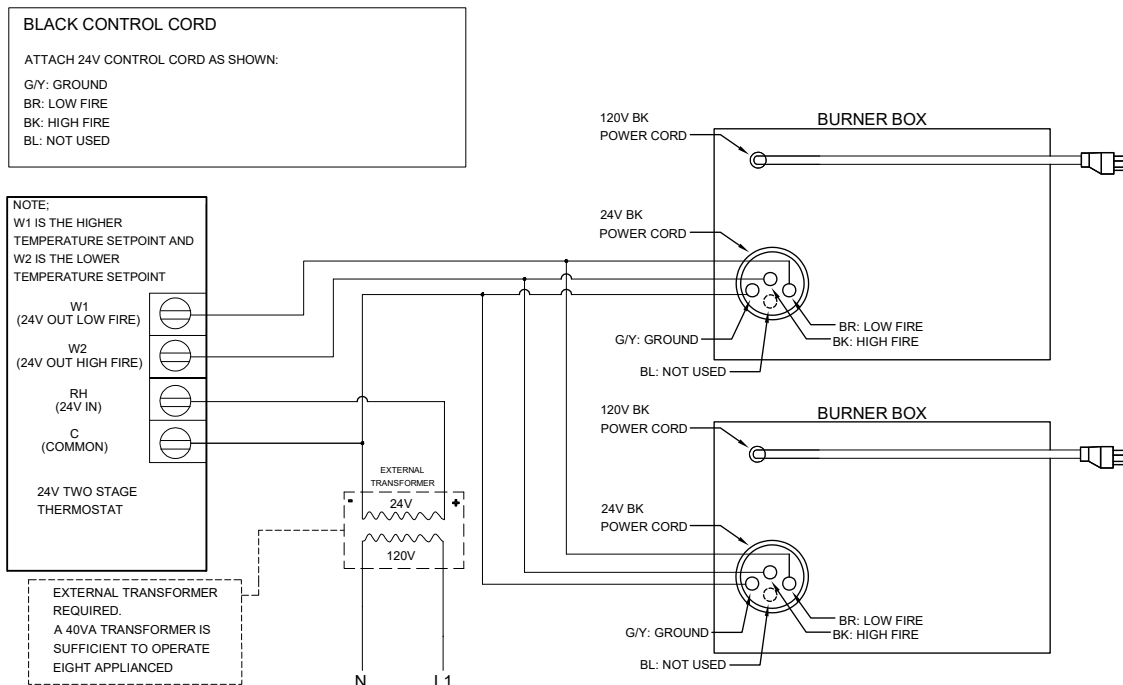

**Before field wiring this appliance - Check existing wiring; replace if necessary.**

**Note:** If any of the original wire supplied with the appliance must be replaced, it must be replaced with wiring material having a rating of at least 600 V, 105° C.

**Figure 2.2 • Internal Wiring Diagram**

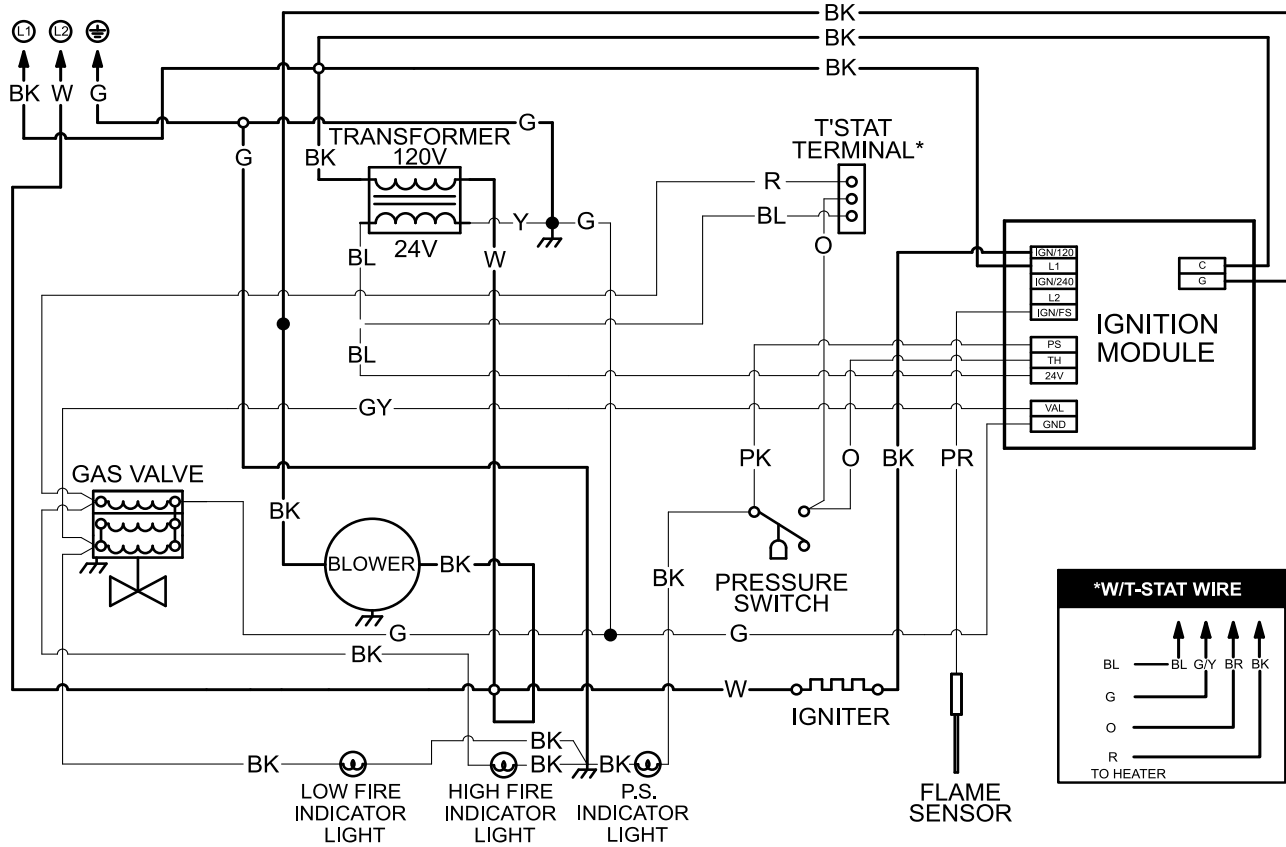

**WIRING INFORMATION:**

**LINE VOLTAGE:**

- FACTORY STANDARD —————
- FACTORY OPTION - - - - -
- FIELD INSTALLED - · - - - -

**LOW VOLTAGE:**

- FACTORY STANDARD —————
- FACTORY OPTION - - - - -
- FIELD INSTALLED - · - - - -

Figure 2.3 • Internal Wiring Diagram with HLRP

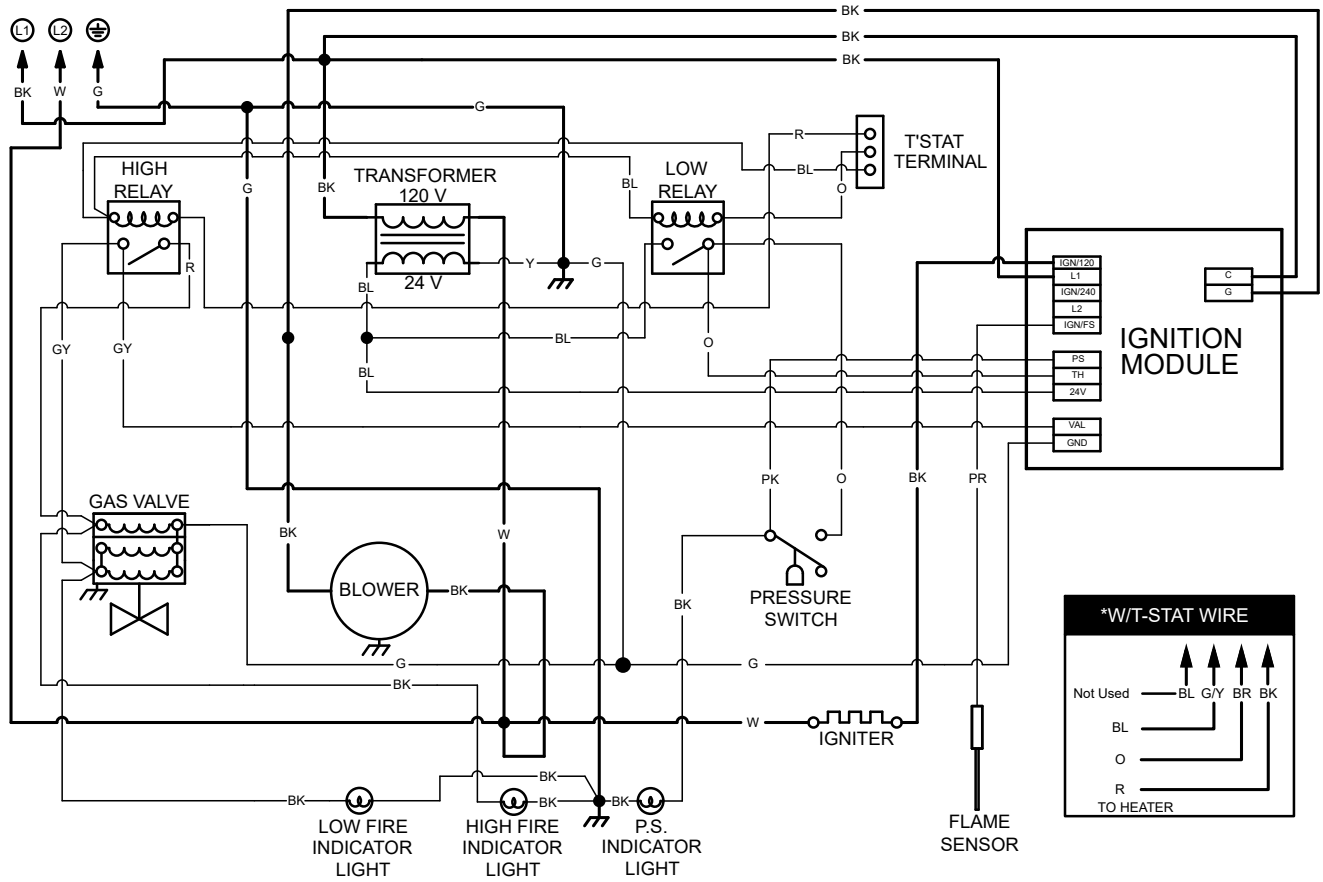

WIRING INFORMATION:

LINE VOLTAGE:

- FACTORY STANDARD —————
- FACTORY OPTION - - - - -
- FIELD INSTALLED - - - - -

LOW VOLTAGE:

- FACTORY STANDARD —————
- FACTORY OPTION - - - - -
- FIELD INSTALLED - - - - -

## Specifications

Chart 2.1 • Specifications

Model Number	Gas Type (select one)	BTU/H (High Fire)	BTU/H (Low Fire)	Straight Length	U-Tube Length	Standard Weight (lbs.)	Stainless Steel Weight (lbs.)	Recommended Mounting Height	Combustion Chamber (Black Coated)	Radiant Emitter Tube(s) (Black Coated)	Radiant Surface Area (sq. ft.)	36" Baffle Sections
HL2-20-65	N or LP	65,000	50,000	21'-7"	13'-0"	120	N/A	9' to 14'	Alum	Alum	20.2	5
HL2-20-75	N or LP	75,000	50,000	21'-7"	13'-0"	120	145	10' to 15'	Alum	Alum	20.2	5
HL2-20-80	N or LP	80,000	52,000	21'-7"	13'-0"	120	N/A	10' to 15'	Alum	Alum	20.2	5
HL2-20-96	N or LP	96,000	65,000	21'-7"	13'-0"	120	N/A	11' to 18'	Alum	Alum	20.2	5
HL2-30-65	N or LP	65,000	50,000	31'-3"	**17'-8"	160	N/A	10' to 15'	Alum	Alum	30.4	4
HL2-30-75	N or LP	75,000	50,000	31'-3"	**17'-8"	160	195	11' to 18'	Alum	Alum	30.4	4
HL2-30-80	N or LP	80,000	52,000	31'-3"	**17'-8"	160	195	11' to 18'	Alum	Alum	30.4	5
HL2-30-100	N or LP	100,000	65,000	31'-3"	**17'-8"	160	195	12' to 20'	Alum	Alum	30.4	5
HL2-30-125	N or LP	125,000	82,000	31'-3"	**17'-8"	160	N/A	13' to 23'	Alum	Alum	30.4	5
HL2-40-65	N or LP	65,000	50,000	40'-11"	22'-8"	190	N/A	11' to 18'	Alum	Alum	40.5	2
HL2-40-75	N or LP	75,000	50,000	40'-11"	22'-8"	190	235	11' to 18'	Alum	Alum	40.5	2
HL2-40-80	N or LP	80,000	52,000	40'-11"	22'-8"	190	235	11' to 18'	Alum	Alum	40.5	2
HL2-40-100	N or LP	100,000	65,000	40'-11"	22'-8"	190	235	12' to 20'	Alum	Alum	40.5	4
HL2-40-125	N or LP	125,000	82,000	40'-11"	22'-8"	190	235	13' to 23'	Alum	Alum	40.5	4
HL2-40-150	N or LP	*150,000	100,000	40'-11"	22'-8"	190	235	14' to 25'	Titan	Alum	40.5	4
HL2-40-175	N or LP	*175,000	125,000	40'-11"	22'-8"	190	N/A	15' to 27'	Titan	Alum	40.5	4
HL2-50-125	N or LP	125,000	82,000	50'-7"	**27'-4"	235	290	15' to 27'	Alum	Alum	50.6	4
HL2-50-150	N or LP	*150,000	100,000	50'-7"	**27'-4"	235	290	15' to 27'	Titan	Alum	50.6	4
HL2-50-175	N or LP	*175,000	125,000	50'-7"	**27'-4"	235	N/A	16' to 30'	Titan	Alum	50.6	2
HL2-50-200	N or LP	*200,000	145,000	50'-7"	**27'-4"	235	N/A	17' to 35'	Titan	Alum	50.6	2
HL2-60-150	N or LP	*150,000	100,000	60'-3"	32'-4"	265	330	16' to 30'	Titan	Alum	60.7	2
HL2-60-175	N or LP	*175,000	125,000	60'-3"	32'-4"	265	N/A	16' to 30'	Titan	Alum	60.7	2
HL2-60-200	N or LP	*200,000	145,000	60'-3"	32'-4"	265	N/A	17' to 35'	Titan	Alum	60.7	2
HL2-70-175	N or LP	*175,000	125,000	69'-11"	**37'-2"	300	N/A	19' to 42'	Titan	Alum	70.9	2
HL2-70-200	N or LP	*200,000	145,000	69'-11"	**37'-2"	300	N/A	19' to 42'	Titan	Alum	70.9	2

\* Model requires stainless steel tube clamp (P/N: TP-220) to be located at the seam between the primary combustion chamber and the secondary combustion tube downstream of the burner control box.

\*\* Model requires 5EA-SUB accessory package when installing in a 'U' configuration (P/N: TF1B).

Titan = Black coated titanium stabilized aluminized steel.

Alum = Black coated aluminized treated steel.

## Tube Installation Sequence

Figure 2.4 • Tube Installation Sequence

**Important!** The combustion chamber & radiant tube sections must be installed in the following order:

20 Foot

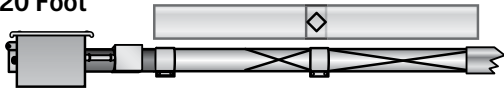

30 Foot

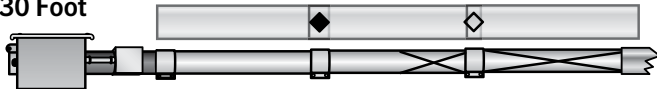

40 Foot

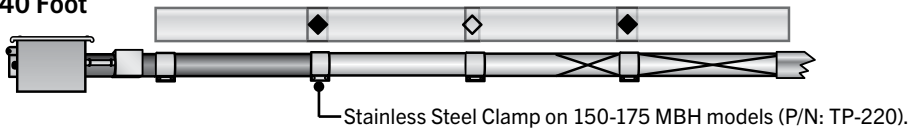

50 Foot

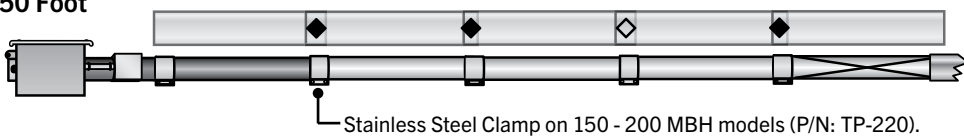

60 Foot

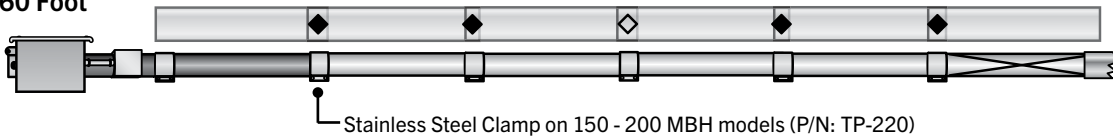

70 Foot

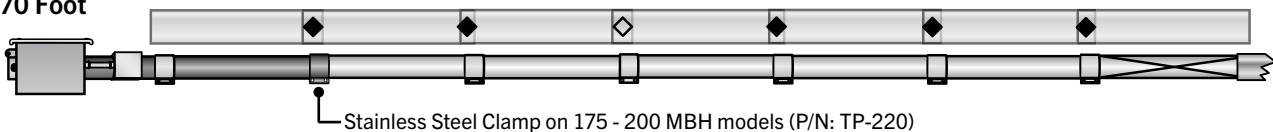

### Key

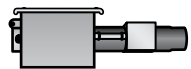

Burner Control Box with  
16" Burner Tube



Standard Tube Clamp



Black Coated Combustion  
Chamber Tube\*



Stainless Steel Tube  
Clamp (P/N: TP-220)  
*150-200 MBH models only - Located  
between 1st and 2nd 10 ft. tube sections.*



Black Coated Aluminized Combustion  
Chamber/ Radiant Emitter Tube



**Baffle Location**

\*Aluminized Steel (50,000 to 125,000 BTU/H models), Alumi-Ti (titanium treated) steel tubes (150,000 to 200,000).

**NOTE:** Reference the Tube Heater General Manual, Chart 3.6 (page 23) for secured reflector joints.

# 3.0 Operation

---

## Sequence of Operation

**Standby:** The circuit board continually checks for internal faults, circuit integrity, and relay contact positioning.

**Starting Circuit:** Upon a call for heat, the control verifies that the differential switch is in the proper position (open). The control energizes the fan. Once operational static pressure is achieved, the differential switch will close initiating the ignition sequence. The glo-bar is powered and the gas valve opens after 45 seconds. If the flame is not sensed, the heater will attempt to re-ignite for a total of three (3) trials for ignition before proceeding to soft lockout.

**Single Stage Running Circuit:** After ignition, the flame rod monitors burner flame. If sense of flame is lost, the control closes the gas valve within one second and a new trial sequence (identical to the starting sequence) is initiated. If flame sense is not established within 8.5 seconds, the heater will attempt two (2) additional ignition sequences before proceeding to soft lockout. The control can be reset by briefly interrupting the power source.

**Two Stage Running Circuit:** The second stage on the gas valve is powered directly from the second stage of the thermostat. In order for two stage to flow to a higher output, single stage must be energized as well. The thermostat determines which stage to maintain for the desired comfort level.

**Shut Down:** When the thermostat is satisfied, the fan will enter a two (2) minute post-purge cycle. Refer to page 13 for diagnostics; soft & hard lockout.

## Thermostat

**NOTE:** Different thermostats operate according to their particular features. Refer to thermostat specifications for details.

HL2 Series heaters require a 24 V, two stage thermostat to operate. The burner control box is equipped with either a round terminal strip that accepts three (3) 1/4-inch insulated female spade terminals or a 36-inch yellow 24 VAC control wire. Do not supply 120 VAC to the 24 VAC connection.

The HL2 Series is equipped with or without a relay board (P/N: HLRP).

### Standard Configuration

**Without relay board** (white terminal label\*):

- Single burner control box.
- Single thermostat.

### Optional Configuration (must be factory installed)

**With relay board** (orange terminal label\*):

- Required when a single thermostat controls two or more burner control boxes or when heaters are common vented.

**NOTE:** Units with a relay board installed must have an external transformer (field supplied), see wiring diagram (Figure 2.1B). Stainless steel heaters with a relay board are indicated with the suffix 'D' on the heater's rating plate.

\*A black 4-core control wire replaces the external terminal plug on stainless steel models or models with water resistant upgrades.

## Diagnostics

### Lockout:

The controls will automatically lockout the heater system when an external or system fault occurs. There are two types of lockout:

**Soft Lockout:** The heater will attempt to light three times. In the event of a failed attempt to light, (gas pressure, valve, no flame sense etc.), the heater will enter Soft Lockout mode for 30 minutes and then attempt to light three more times before entering Hard Lockout mode.

**Hard Lockout:** If proof of flame is not established, a component failure occurs or blockages are evident, the heater will enter hard lockout. If lockout occurs, the control can be reset by briefly interrupting the power source. Refer to Chart 3.1 below for a description of LED codes.

**Figure 3.1 • LED Operational Indicator Lights**

**Note:** Hard Lockout LED CODE will appear upon completion of the soft lockout sequence of operation.

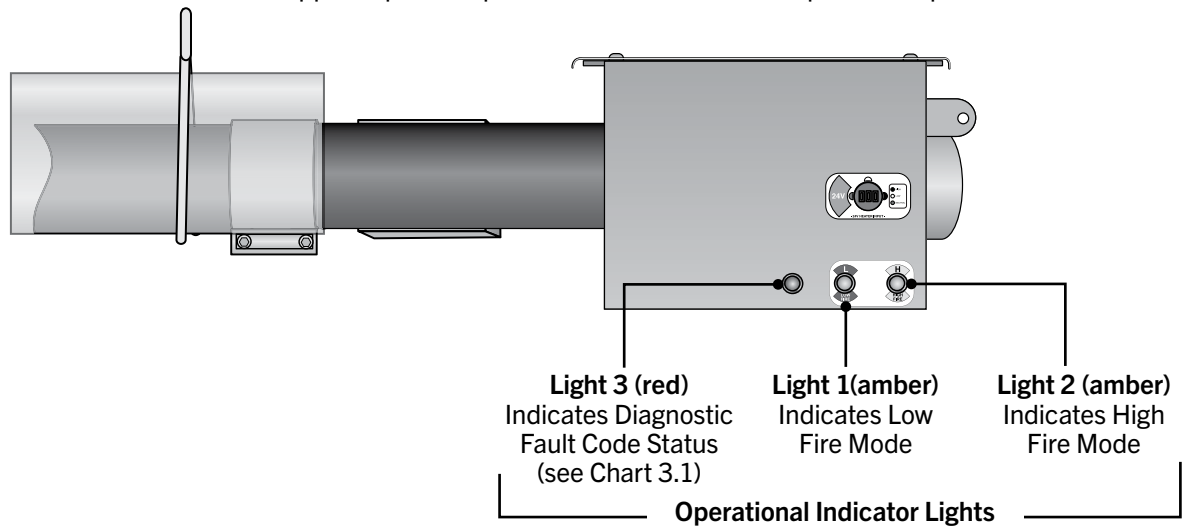
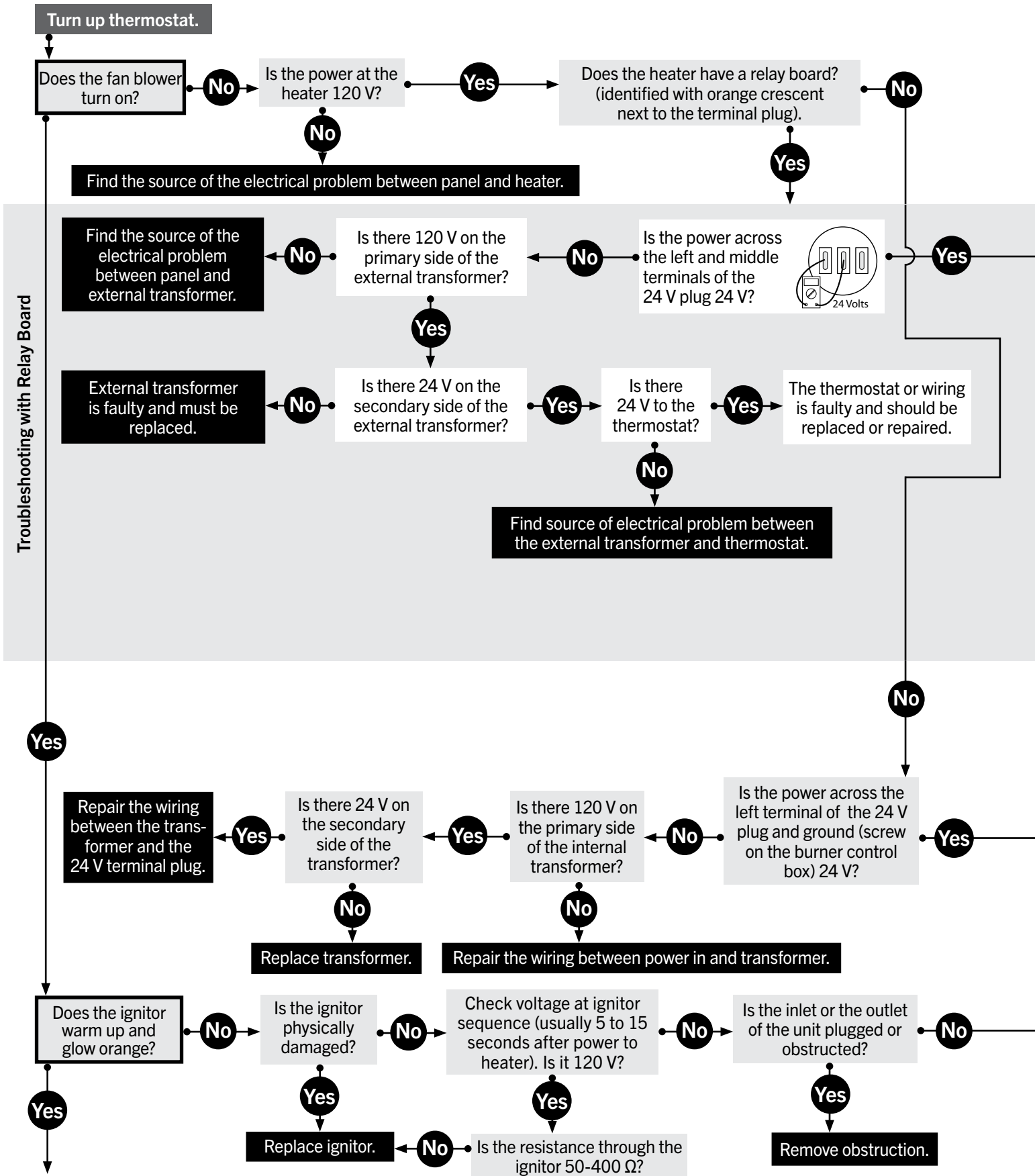

**Chart 3.1 • LED Fault Code Status**

LED Code	Fault Status	Fault Code Delay*
Initial flash on power up, then steady off	No fault, normal operation	No delay
Steady ON	Module failure / Internal fault	No delay
1 flash	Ignition failure	30-32 minutes
2 or 3 flashes	APS (Air Proving Switch) Fan / Intake / Exhaust	10-12 minutes
4 flashes	Solenoid valve fault Leaky valve Flame amplifier fault	No delay
No flash on 117 V startup	Transformer fault	No delay

\*Some flash codes have a time delay before the LED will flash.

# 4.0 Troubleshooting Guide



Continued on page 16

**NOTICE**

Bypassing any switch is intended for testing purposes only. Do not leave switch bypassed during normal operation or the heater's built-in safety mechanisms will be compromised.

Key				
<b>Without Relay Board:</b>		<b>With Relay Board:</b>		
<div style="display: flex; align-items: center; gap: 5px;"> <div style="width: 20px; height: 20px; background-color: #e0e0e0; border: 1px solid black;"></div> Start Question                 </div>	<div style="display: flex; align-items: center; gap: 5px;"> <div style="width: 20px; height: 20px; background-color: #d3d3d3; border: 1px solid black;"></div> Process Question                 </div>	<div style="display: flex; align-items: center; gap: 5px;"> <div style="width: 20px; height: 20px; background-color: black;"></div> Corrective Action                 </div>	<div style="display: flex; align-items: center; gap: 5px;"> <div style="width: 20px; height: 20px; background-color: white; border: 1px solid black;"></div> Process Question                 </div>	<div style="display: flex; align-items: center; gap: 5px;"> <div style="width: 20px; height: 20px; background-color: black;"></div> Corrective Action                 </div>

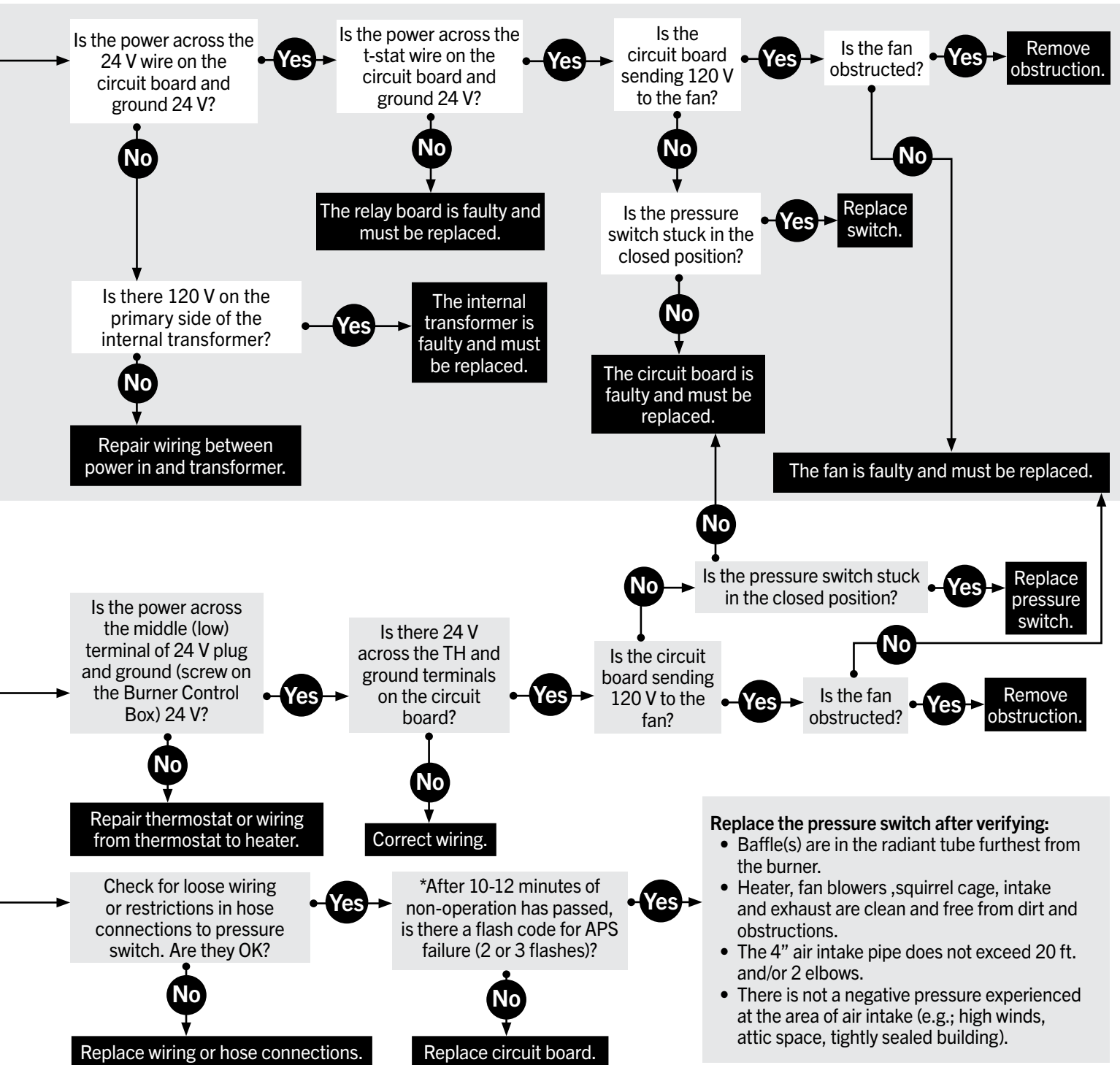

\* Refer to LED diagnostic Fault Code Chart.

Continued from page 14

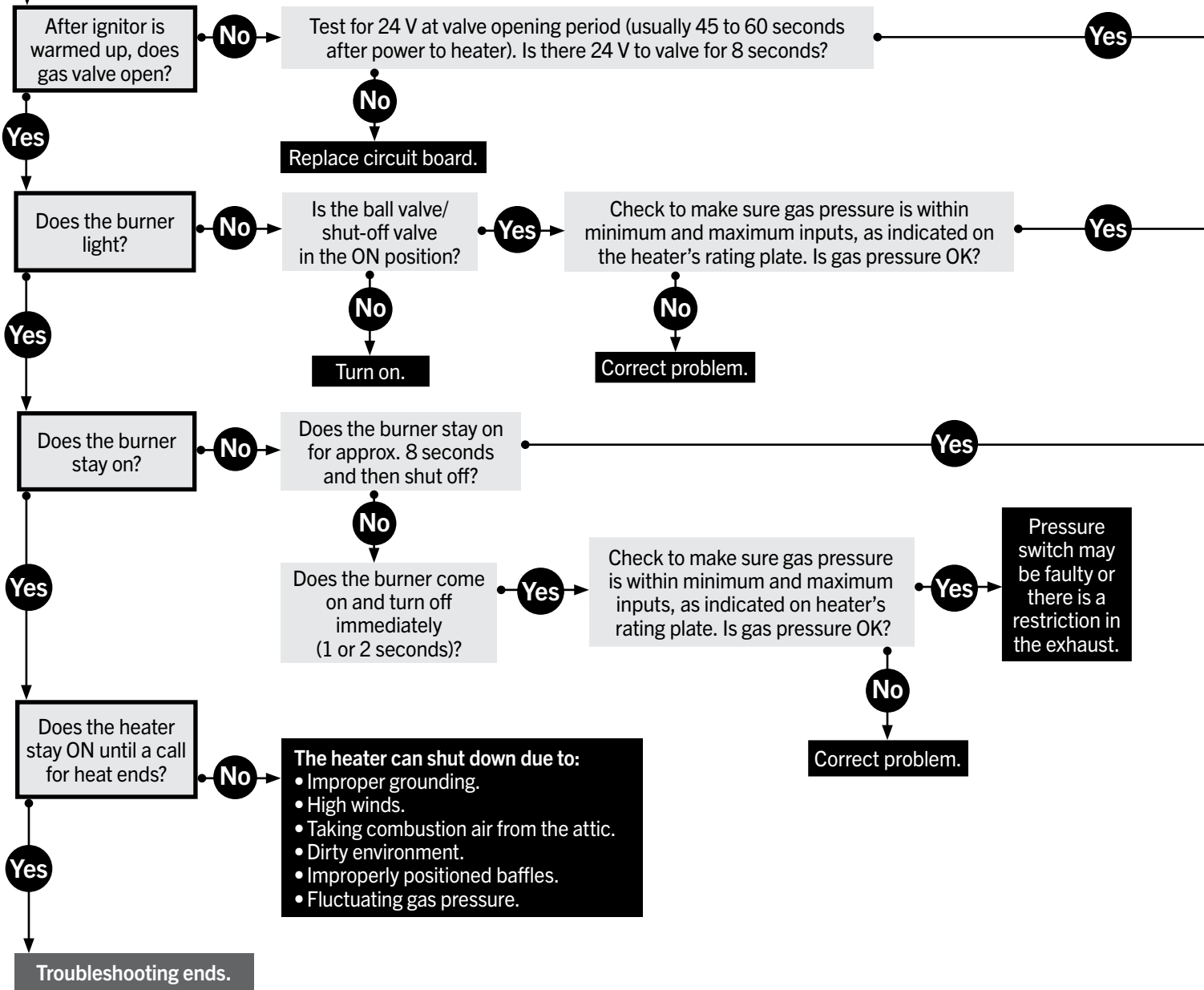

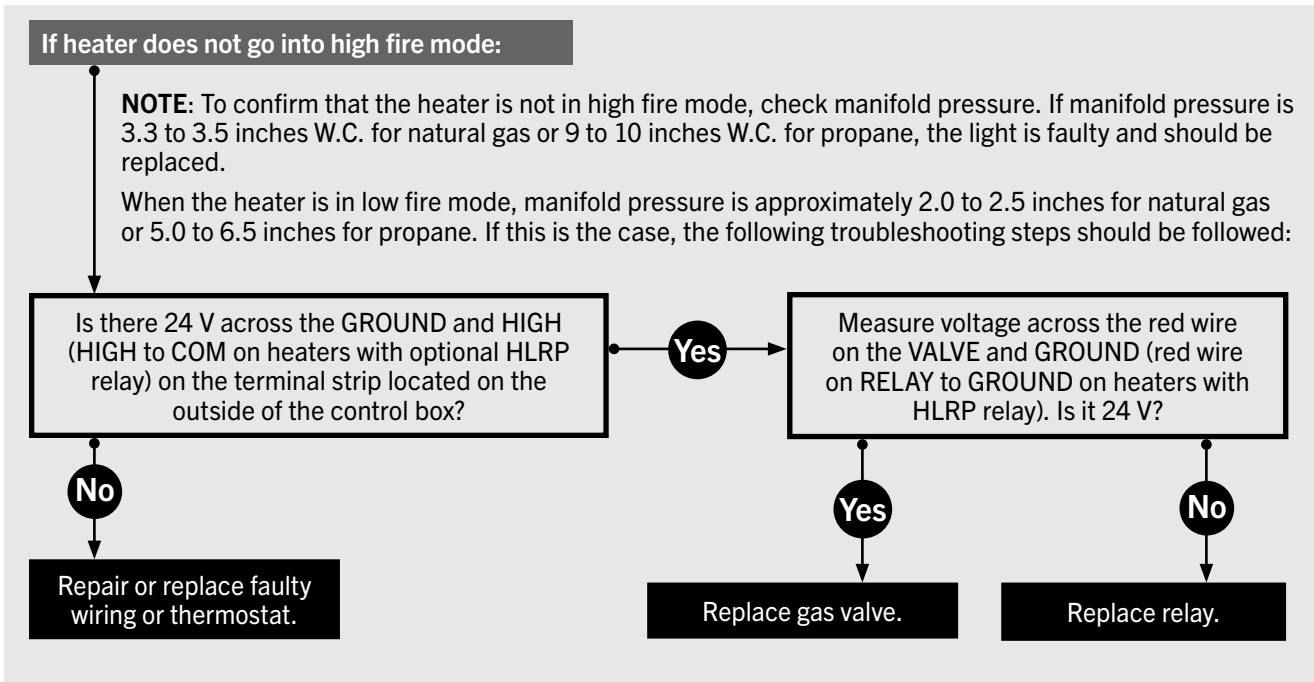
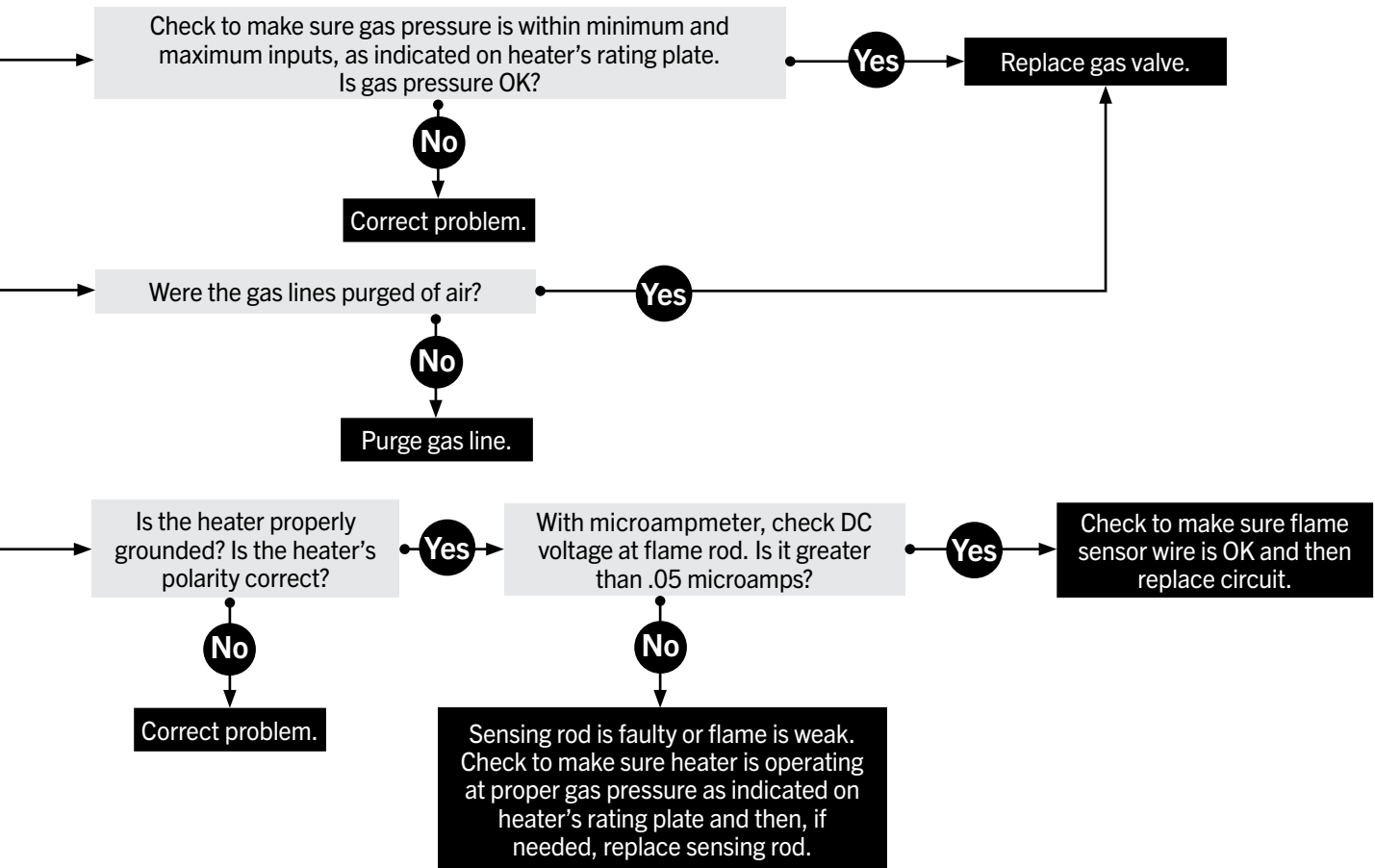

# 5.0 Parts

Figure 5.1 • Burner Assembly Components

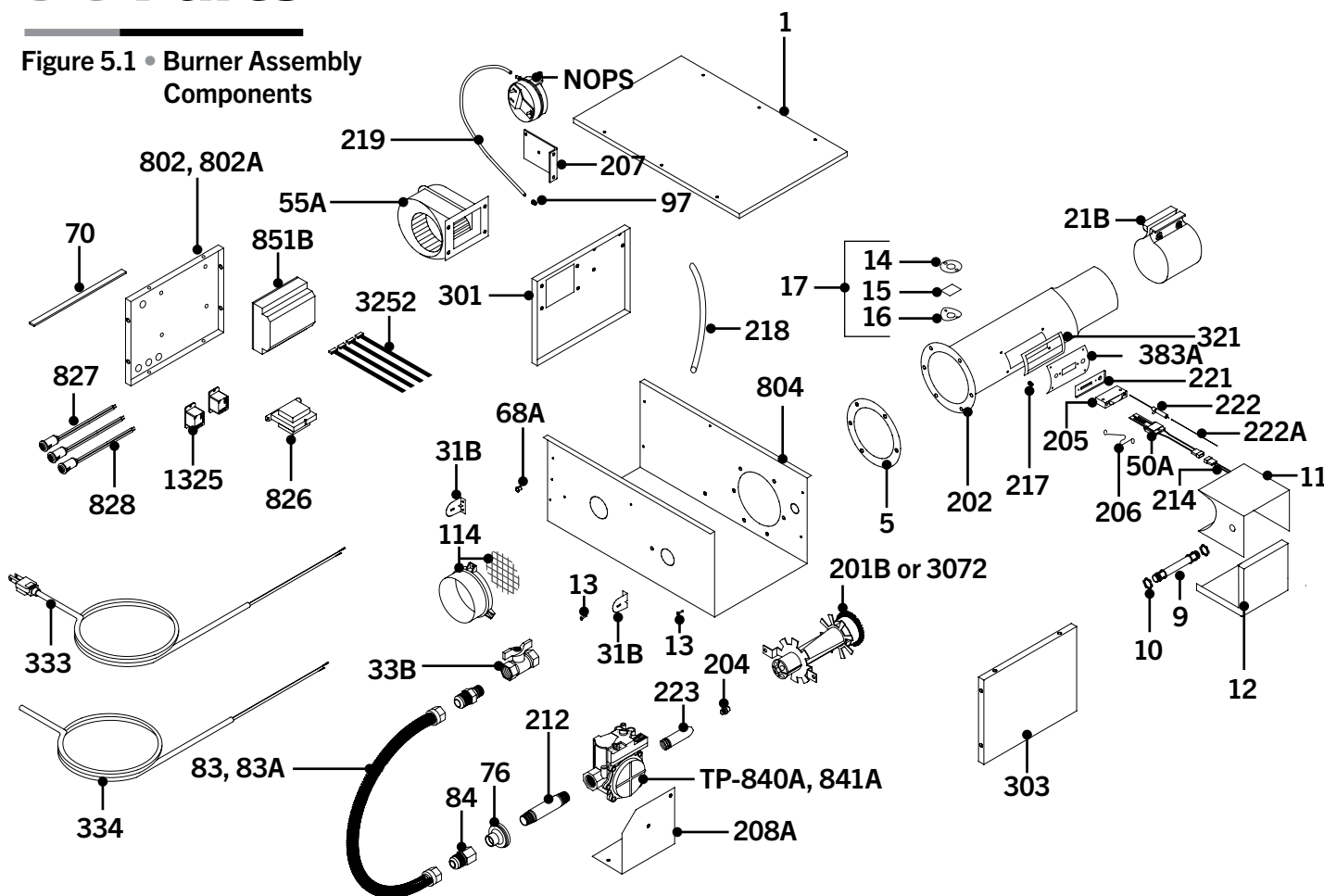

Chart 5.1 • Parts List

Part No.	Description	Part No.	Description
TP-1	Control Box Cover	TP-26E	10 ft. 409 Stainless Steel Combustion Tube*
TP-5	Flange Gasket	TP-31B	Control Box Mounting Bracket
TP-9	Conduit Coupling	TP-33B	1/2" Shut-Off Ball Valve / Inlet Tap
TP-10	Conduit 4" x 1/2"	TP-50A	Glo-Bar™ Ignitor
TP-11	Glo-Bar™ Ignitor Box	TP-55A	Fan Blower
TP-12	Glo-Bar™ Ignitor Box Cover	TP-65I	36" Interlocking Turbulator Baffle
TP-13	8 x 1/2" Self-Drilling Screw	TP-68A	Strain Relief Bushing
TP-14	Sight Glass Gasket	TP-70	Control Box Cover Gasket (per foot**)
TP-15	Sight Glass	TP-76	Rubber Grommet
TP-16	Sight Glass Washer	TP-82	Reflector Center Support (RCS)
TP-17	Sight Glass Kit	TP-83	24" Stainless Steel Flexible Gas Connector
TP-19B	4" Wire Hanger with Tension Spring	TP-83A	24" PVC Coated S.S. Flexible Gas Connector*
TP-20C	120" Aluminum Reflector	TP-84	1/2" Female/Male Flare Fitting
TP-20D	120" Stainless Steel Reflector*	TP-97	1/4" x 1/4" Brass Int./Ext. Atmos. Barb Fitting
TP-21B	4" Standard Tube Clamp	TP-105	Aluminum Reflector End Cap
TP-26A	10 ft. Aluminized Radiant / Combustion Tube	TP-106	Reflector End Cap Clips (8 pcs.)
TP-26B	10 ft. Titanium Coated Combustion Tube	TP-113	Reflector Tension Spring
TP-26D	10 ft. 304 Stainless Steel Radiant Tube*	TP-114	Plastic Air Orifice with Screen

\* May be used with stainless steel upgrades.

\*\* 6 feet total required to cover outer edges of the burner control box.

Figure 5.2 • Tube and Reflector Components

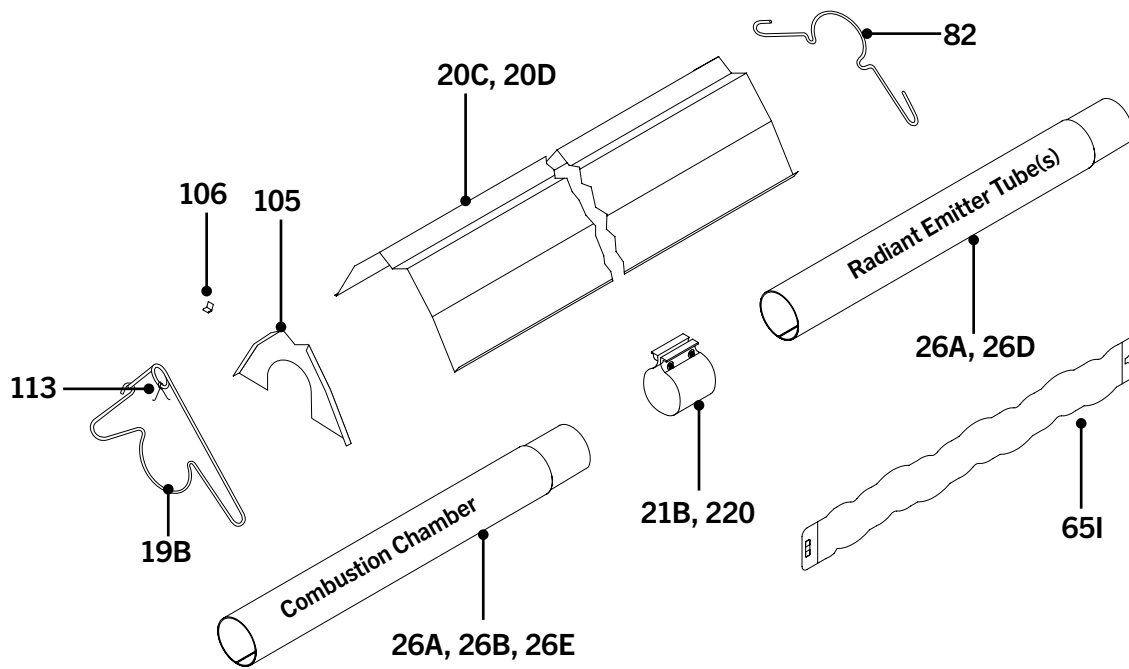





Part No.	Description	Part No.	Description
TP-201B	Burner (Tan) - consult factory	TP-333	60 in. Black 120 V Power Cord with Ground
TP-202	16" HSI Burner Tube with Flange	TP-334	Black 4-Core Control Wire
TP-204	Gas Orifice (consult factory)	TP-383A	Glo-Bar™ Ignitor Plate
TP-205	Glo-Bar™ Holder	TP-802	End Panel, Left (with relay board)
TP-206	Glo-Bar™ Holder Spring Clip	TP-802A	End Panel, Left
TP-207	Pressure Switch Mounting Bracket	TP-804	Burner Control Box Outer Shell
TP-208A	Gas Valve Mounting Bracket	TP-826	40 VA Transformer
TP-212	1/2" x 3" Pipe Nipple	TP-827	Red LED Display Diagnostic Light
TP-214	Glo-Bar™ Wiring Harness	TP-828	Yellow Operational Indicator Light
TP-217	Pressure Switch Barb	TP-840A	36G54-224 Gas Valve - Natural Gas Assembly
TP-218	Differential Switch Vinyl Sensing Tube (exhaust)	TP-841A	36G54-226 Gas Valve - LP Gas Assembly
TP-219	Differential Vinyl Sensing Tube (burner)	TP-851B	35-66 Diagnostic Circuit Board
TP-220	Stainless Steel Tube Clamp (150 & 200 MBH)*	TP-NOPS	Normally Open Pressure Switch (see below)
TP-221	Glo-Bar™ Holder Gasket	TP-264B	Differential Pressure Switch, 65 to 100 MBH
TP-222	Flame Rod	TP-264E	Differential Pressure Switch, 125 to 150 MBH
TP-222A	Flame Rod Wire	TP-264D	Differential Pressure Switch, 175 MBH
TP-223	Gas Manifold	TP-264F	Differential Pressure Switch, 200 MBH
TP-301	Burner Control Box Center Panel	TP-1325	Optional HLRP Isolation Relay (Qty. 2)
TP-303	End Panel, Right	TP-3072	Burner (Green) - consult factory
TP-321	Ignition Plate Gasket	TP-3252	4-Piece Wire Harness Set

\* May be used with stainless steel upgrades.

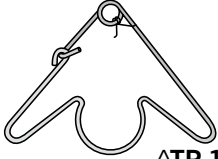
## Kit Contents Check List

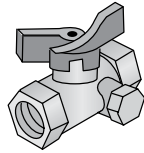
Chart 5.2 • Kit Contents for HL2 Series - Reference the length column for your model

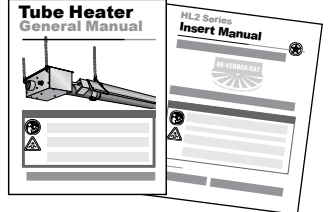
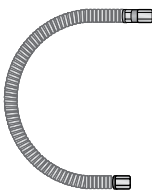
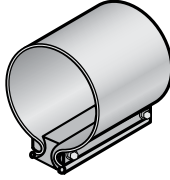
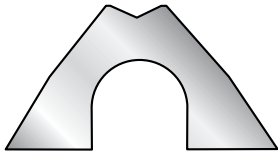
HL2 Series Kit Contents							
<p><b>TP-19B</b> 4" Hanger with Reflector Tension Spring</p>  <p>^TP-19C</p>	<p><b>TP-82</b> 4" Reflector Center Support (RCS)</p>  <p>^TP-829</p>	<p><b>TP-33B</b> 1/2" Shut-Off Valve (Ball Valve &amp; Inlet Tap)</p> 	<p><b>TP-106</b> Reflector End Cap Clips</p> 	<p><b>TP-25**</b> 1/4" Female Spade Terminal</p> 	<p>Tube Heater General Manual and HL2 Series Insert Manual F/N: LIOGTa &amp; LIOHL2a</p> 		
<p><b>TP-83</b> 24" Stainless Steel Flexible Gas Connector</p>  <p>^TP-83A</p>	<p><b>TP-21B*</b> 4" Tube Clamp</p>  <p>^TP-220</p>	<p><b>TP-105</b> Reflector End Cap</p>  <p>^TP-105A</p>					
Part No.	Description	20 ft.	30 ft.	40 ft.	50 ft.	60 ft.	70 ft.
TP-19B	4" Hanger w/ Tension Spring	3	4	5	6	7	8
TP-21B	4" Tube Clamp	2	3	4	5*	6*	7*
TP-25	1/4" Female Spade Terminal**	3	3	3	3	3	3
TP-33B	1/2" Shut-Off Valve & Inlet Tap	1	1	1	1	1	1
TP-82	4" Reflector Center Support	2	3	4	5	6	7
TP-83	24" S.S. Flexible Gas Connector	1	1	1	1	1	1
TP-105	Reflector End Cap	2	2	2	2	2	2
TP-106	Reflector End Cap Clips	8	8	8	8	8	8
LIOGTa	General Tube Heater Manual	1	1	1	1	1	1
LIOHL2	HL2 Series Insert Manual	1	1	1	1	1	1
Filled By:							

\* **NOTE:** One 4" stainless steel tube clamp (P/N: TP-220) is provided for each 150,000 - 200,000 BTU model. Place as shown on page 11.

\*\* Not included with models installed with yellow control cord.

^ Part number for models upgraded with stainless steel options.

### Approvals

- CSA
- Indoor approval
- Outdoor approval with OD-Kit
- Commercial approval

### Limited Warranty

- 3 years - Burner box components
- 5 years - Combustion and radiant tubes
- 10 years - Stainless steel burner
- See page 40 of the General Tube Heater Manual for terms and conditions.



© 2025 Detroit Radiant Products Co.  
21400 Hoover Road • Warren, MI 48089  
Phone: (586) 756-0950 Fax: (586) 756-2626  
www.detroitradiant.com • sales@drp-co.com

